



AQUAEDGE greenspeed
PUREtec

Carrier AquaEdge[®] 19DV Centrifugal Chiller

EquiDrive™
Back-to-Back Compressor

PUREtec™
Low GWP Refrigerant

Greenspeed™
Intelligence

Cooling Capacity: 300 - 800Ton
(Air-conditioning Low Voltage VFD)





In 1998, Time magazine named Dr. Carrier one of its 20 most influential builders and titans of the 20th century.

Carrier is a leading global provider of innovative HVAC, refrigeration, fire, security and building automation technologies. Supported by the iconic Carrier name, the company's portfolio includes industry-leading brands such as Carrier, Kidde, Edwards, LenelS2 and Automated Logic. Carrier's businesses enable modern life, delivering efficiency, safety, security, comfort, productivity and sustainability across a wide

range of residential, commercial and industrial applications.



Model Number Nomenclature

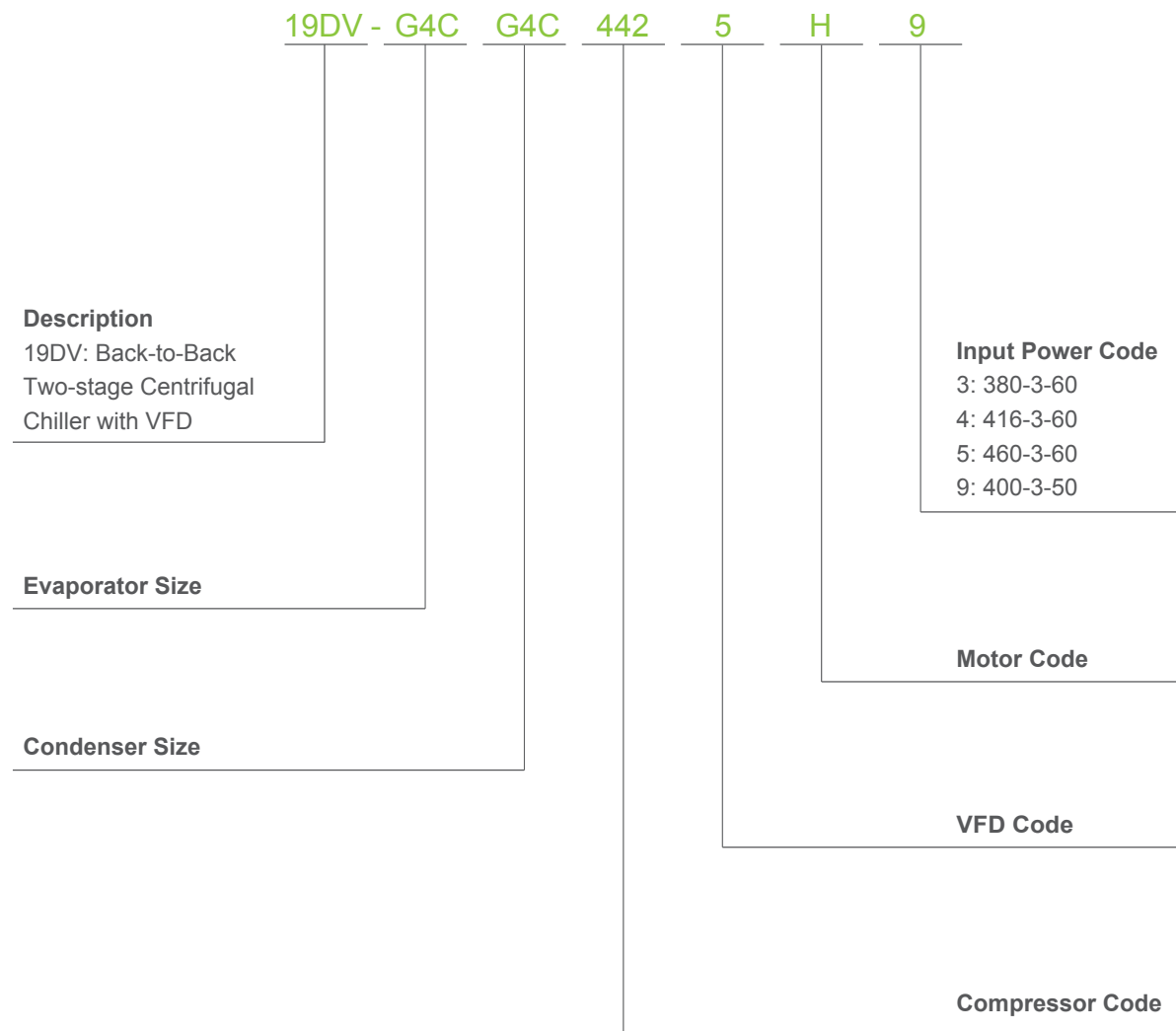

Cooling Capacity

300 - 800Ton (Air-conditioning Low Voltage VFD)



Reliable

- Simple and robust refrigerant lubricated ceramic bearing system without the limitations of conventional oil lubricated chillers. Customers won't be troubled by oil related failures as well as maintenance cost.
- Advanced back-to-back two-stage compressor naturally balances both radial and axial thrust on shaft.
- 19DV is equipped with latest generation of Carrier's Variable-Frequency Drive along with IP54 cabinet, which provides high level protection to the electrical components inside from dirt and water outside.
- High tier variable speed starter equipped with harmonic filter(optional), total harmonic distortion (THD) $\leq 5\%$ and fully complies with IEEE519 standard.
- Swift restart - 19DV can restart within 30 seconds (with UPS) after power recovery (There would be around 5-seconds tolerance due to different site conditions.) and quickly regain capacity, providing added reliability for mission critical facilities such as data center applications.

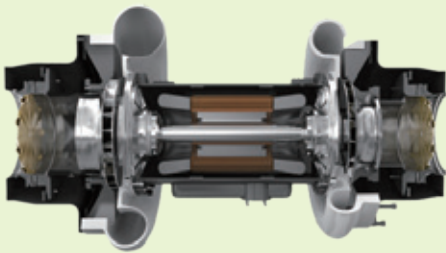

Efficient

- 19DV chillers can achieve up to 7.3 full load COP_R and 12.3 IPLV_{IP} at AHRI conditions.
- Carrier back-to-back two-stage compressor integrated with inter-stage economizer which improves both cooling capacity and efficiency.
- High speed direct drive motor reduces mechanical loss by 75% resulting from the removal of gear driven system.
- With the application of refrigerant lubricated bearings, potential efficiency drop through oil logging of the heat exchangers is eliminated in 19DV.
- Pioneer falling film evaporator is designed for low pressure refrigerant, which brings significantly enhanced heat transfer efficiency by mitigating submergence effect especially at part load conditions.
- High performance tubing with internally and externally enhanced fins improves chiller efficiency by reducing overall heat transfer resistance.
- Greenspeed™ variable speed control gives a instantaneous control of compressor speed to adapt building load changes perfectly, which ensures that the chiller is always operating efficiently at both full load and part load.

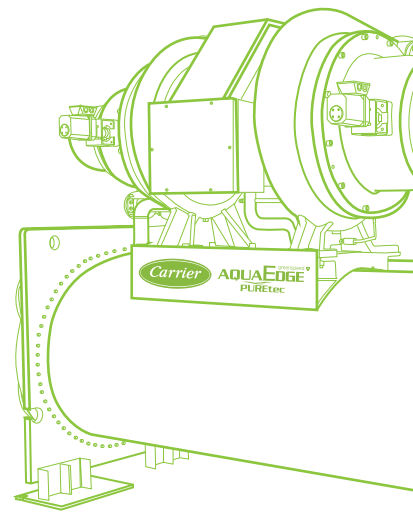
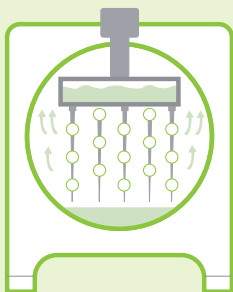

Sustainable



- ✔ R-1233zd(E) is new non-Ozone Depletion Substances, the low Global Warming Potential of ~ 1, non-flammability and non-toxic refrigerant that provides a safe and environmental solution to centrifugal chillers.
- ✔ Carrier pioneer falling film evaporator design helps reduce the refrigerant charge significantly.
- ✔ The industry leading energy efficiency of 19DV chiller leads to lower electrical power consumption and significant reduction of related CO₂ emissions.

PUREtec

R-1233zd(E)

Quiet



- ✔ Refrigerant-cooled hermetic motor, direct drive, optimized flow channel and 60% impeller speed of legacy design, all these features contribute to the overall compressor sound reduction.
- ✔ Greenspeed™ variable speed control adaptively turns down impeller speed at part load for better acoustic performance.
- ✔ 19DV chillers can meet 18001 standard recommended by Occupational Health and Safety Advisory Services (OHSAS).

Flexible



- ✔ System layout of 19DV chillers is well optimized and specific crescent shape economizer is designed to best leverage the space between evaporator and condenser that delivers up to -15% smaller footprint versus legacy R-123 unit.
- ✔ Patented re-locatable control panel could be installed at any of the four corners of the chiller, which makes the layout of chillers more flexible to fit the site conditions.
- ✔ Bolt connection modular design is ideal for retrofit project or installation in limited place.
- ✔ Miscellaneous optional offerings (such as marine water box) help to facilitate daily maintenance on jobsite.

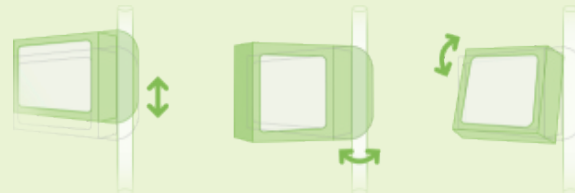

Smart



- ✔ Carrier SmartView™ control - color touch screen, intuitive menu, animated component level interface, graphic trending, auto pushed alarm mail, smart password and up to 10 languages for choice.
- ✔ Multiple remote access methods present the users a flexible way to monitor and control the chillers.
- ✔ Carrier Smart Service supports online data management and analysis, daily and key performance reports, prognostics and preventative maintenance, which will help the users continuously optimize the chiller and system operation.



CERTIFIED
www.ahridirectory.org

and 551/591

Carrier SmartView™ Control

User-friendly Interface

AquaEdge® 19DV centrifugal chiller equips with the latest Carrier SmartView™ control system which provides powerful control and monitoring functions for smart chiller operation. The control system applies a 10 inch high resolution colorful touch screen, which supports up to 10 languages, and real time display of operation parameters with pictures makes it more user-friendly.

Smart Operation

- Carrier SmartView™ control system provides customer the smart password function to avoid any setting change without authorization.
- When the chiller receives a start-up command, the controller will conduct following pre-start safety checking, to ensure parameters like condensing pressure, bearing temperature, motor winding temperature, discharge temperature, evaporator saturated temperature and average line voltage, etc. are in normal condition.
- Optimized intelligent and dynamic control algorithm ensures effective and reliable operation. Carrier SmartView™ control system can not only monitor and display main operation parameters with real-time trend, but also record the history data of each key component.
- Carrier SmartView™ control system provides comprehensive protections for long-term stable operation, such as surge protection, overvoltage and overcurrent protection, discharge temperature overheat protection, bearing temperature overheat protection, evaporator and condenser anti-freeze protection, low discharge superheat protection etc..
- The optional Envelope Stability Control is an advanced solution to balance the chiller efficiency and reliability at very low load. The controller optimizes compressor speed, inlet guide vane position and stabilizer valve position to find the most efficient operating point throughout the operating range without compromising the chiller stability in real time.
- Optional Master-Slave function enables two chillers work in Master-Slave mode with CCN communication. Two chillers can be in series or parallel connection. Carrier patent control algorithm can make two chillers achieve a good balance between efficiency and stability.

Intelligent Diagnosis

- Carrier SmartView™ control system integrates with effective failure diagnostic functions. Once control system detects failure, the alarm will be initiated and related codes will be recorded in alarm menu and it will be saved by control system automatically. Only Carrier certified service technician can read or deleted it by Carrier Service Tool.
- Additional pre-diagnostic function is specialized for maintenance purpose, which could help guide customer replace the parts periodically for safety operation.
- Email alarm function is standard integrated in Carrier SmartView™ control system, which can automatically send out an email with one or more alarm information to specified email address once system goes wrong if Carrier SmartView™ controller is connected to the Internet.

Easy Connection with Building Automation System

- Carrier SmartView™ control panel supports BACnet or Modbus protocol, with which chiller can seamlessly connect with the Building Automation System or the i-Vu™/WebCTRL Control network.
- With the powerful i-Vu™ Link (optional), user can integrate all plant equipment into i-Vu™ Building Automation System. The i-Vu™ Building Automation System provides everything user needs to access, manage, and control your building, including the powerful i-Vu™ user interface, plug-and-play BACnet or Modbus controllers and state-of-the-art Carrier equipment.
- Carrier provides WebCTRL as an additional option to provide similar function like i-Vu™ Link. If you have any questions, please contact with Carrier local agents.

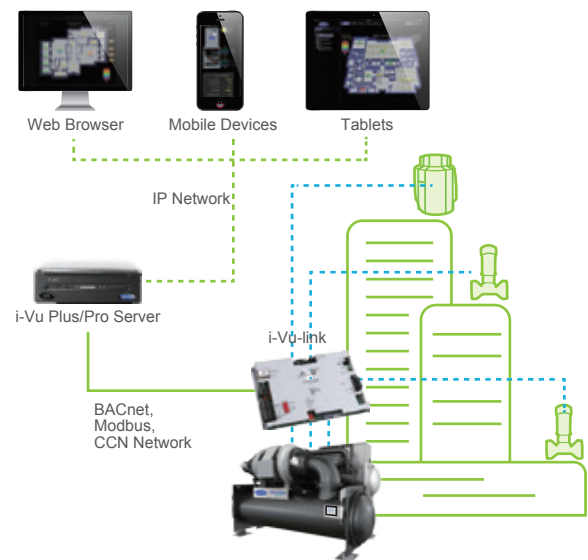

The i-Vu™ Building Automation System

Smart Chiller

Using wireless cellular communications technologies, Carrier® SMART Service continuously streams operating data to the cloud in real time directly from your chiller's Carrier SmartView™ controller. The data is then captured within our IoT platform for ongoing insight into your chiller's health.

Features:

- ✔ Integrated equipment sensors that capture key operating data
- ✔ Secure wireless connectivity to Carrier's cloud-based IoT platform
- ✔ Persistent and reliable data transmission



Smart Cloud

Carrier® SMART Service continuously stores and assesses equipment operating data and service history, comparing it to established values for analytics and data validation. It compares this data to design specifications and matches it against allowable ranges, allowing Carrier to deliver pre-emptive service solutions as needed.

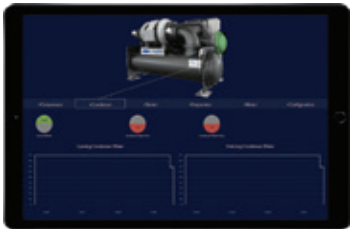

An added benefit, by phases and ultimately, all Carrier service agreement customers will have access to the Carrier® SMART Service Community – a home page that helps you manage your HVAC system assets, such as initiating a service or maintenance request, monitoring work progress, planning for upcoming tasks or reviewing prior work orders. Combined with the information provided by the equipment dashboard, the Community ensures every Carrier service agreement customer has the ultimate in asset management capability.

Features:

- ✔ Complete visibility into your system's performance, energy usage and service history
- ✔ Advanced diagnostics and analytics providing actionable insights

Smart Technician



Carrier® SMART Service changes how equipment is serviced and maintained. Carrier service technicians now utilize mobile devices with remote access to put real-time chiller data and service history in the palm of their hands. With advance notification of problems, technicians arrive at the jobsite more informed, which leads to faster problem resolution and reduced mean time to repair.

Features:

- ✔ Advance notification
- ✔ Remote detection and diagnosis

Air-conditioning (400V-3ph-50Hz)

Model	Chiller						Evaporator			Condenser			Unit Dimensions			Weight		
	Cooling Capacity		Input Power	Full load COP _R	IPLV _{IP}	Chiller Line Amps	Flow Rate	Pressure Drop	Water Connection	Flow Rate	Pressure Drop	Water Connection	Length	Width	Height	Operating	Rigging (w/o Refrigerant)	Refrigerant Charge
	kW	Tons	kW	W/W	W/W	A	l/s	kPa	mm	l/s	kPa	mm	mm	mm	mm	kg	kg	kg
19DV-F20F223345B9	1055	300	151.5	6.966	10.91	247	45.36	29.6	DN300	56.15	19.7	DN250	4596	2469	2852	13799	12379	343
19DV-F21F223345B9	1231	350	174.9	7.036	11.40	285	52.92	33.9	DN300	65.42	27.1	DN250	4596	2469	2852	13874	12429	345
19DV-F40F423345B9	1407	400	201.0	7.000	11.78	327	60.49	59.2	DN300	74.82	40.1	DN250	5116	2469	2852	14450	12919	374
19DV-F42F423545B9	1583	450	224.4	7.054	11.73	365	68.05	50.6	DN300	84.09	50.7	DN250	5116	2469	2852	14686	13066	401
19DV-F43F423645D9	1758	500	250.3	7.025	11.40	406	75.61	50.5	DN300	93.48	62.6	DN250	5116	2469	2852	14836	13154	425
19DV-F43F433645D9	1934	550	279.9	6.911	11.57	442	83.17	60.9	DN300	103.0	61.2	DN250	5116	2469	2852	15033	13279	449
19DV-G43G424425B9	2110	600	291.7	7.235	12.05	456	90.73	53.5	DN350	111.8	65.9	DN250	5201	2629	3058	17290	15101	561
19DV-G44G444525B9	2286	650	318.1	7.186	12.06	514	98.29	50.1	DN350	121.2	52.9	DN250	5201	2629	3058	17889	15505	596
19DV-H43H424625B9	2462	700	344.7	7.142	12.06	546	105.8	46.0	DN350	130.6	53.6	DN300	5206	2832	3229	19819	17302	625
19DV-H44H434625B9	2638	750	372.6	7.080	12.19	579	113.4	43.4	DN350	140.1	50.4	DN300	5206	2832	3229	20286	17611	657
19DV-H43H444625D9	2813	800	405.8	6.932	12.16	652	121.0	59.8	DN350	149.8	47.6	DN300	5206	2832	3229	20708	17999	677

Air-conditioning (380V-3ph-60Hz)

Model	Chiller						Evaporator			Condenser			Unit Dimensions			Weight		
	Cooling Capacity		Input Power	Full load COP _R	IPLV _{IP}	Chiller Line Amps	Flow Rate	Pressure Drop	Water Connection	Flow Rate	Pressure Drop	Water Connection	Length	Width	Height	Operating	Rigging (w/o Refrigerant)	Refrigerant Charge
	kW	Tons	kW	W/W	W/W	A	l/s	kPa	mm	l/s	kPa	mm	mm	mm	mm	kg	kg	kg
19DV-F20F223345B3	1055	300	151.4	6.969	10.91	259	45.36	29.6	DN300	56.14	19.7	DN250	4596	2469	2852	13799	12379	343
19DV-F21F223345B3	1231	350	174.9	7.038	11.40	300	52.92	33.9	DN300	65.42	27.1	DN250	4596	2469	2852	13874	12429	345
19DV-F40F423345B3	1407	400	200.9	7.003	11.78	344	60.48	59.2	DN300	74.81	40.1	DN250	5116	2469	2852	14450	12919	374
19DV-F42F423545B3	1583	450	224.3	7.058	11.73	384	68.05	50.6	DN300	84.08	50.7	DN250	5116	2469	2852	14686	13066	401
19DV-F43F423645D3	1758	500	250.3	7.025	11.40	422	75.61	50.5	DN300	93.48	62.6	DN250	5116	2469	2852	14836	13154	425
19DV-F43F433645D3	1934	550	279.7	6.915	11.57	459	83.17	60.9	DN300	103.0	61.2	DN250	5116	2469	2852	15033	13279	449
19DV-G43G424425B3	2110	600	293.3	7.194	12.00	502	90.73	53.5	DN350	111.8	66.0	DN250	5201	2629	3058	17301	15111	561
19DV-G44G444525B3	2286	650	317.8	7.193	12.06	534	98.29	50.1	DN350	121.2	52.9	DN250	5201	2629	3058	17889	15505	596
19DV-H43H424625B3	2462	700	344.4	7.149	12.06	567	105.8	46.0	DN350	130.6	53.6	DN300	5206	2832	3229	19819	17302	625
19DV-H44H434625B3	2638	750	373.4	7.063	12.15	637	113.4	43.4	DN350	140.1	50.4	DN300	5206	2832	3229	20590	17915	657
19DV-H43H444625D3	2813	800	405.4	6.941	12.16	678	121.0	59.8	DN350	149.8	47.6	DN300	5206	2832	3229	20708	17999	677

Notes:

- The above selections are based on standard AHRI condition.
Leaving evaporator water temperature 44°F (6.7°C), entering evaporator water temperature 54°F (12.2°C).
Entering condenser water temperature 85°F (29.4°C), leaving condenser water temperature 94.3°F (34.6°C).
Evaporator water fouling factor: 0.000100 h·ft²·°F/Btu (0.0180 m²·K/kW), condenser water fouling factor: 0.000250 h·ft²·°F/Btu (0.0440 m²·K/kW).
Evaporator and condenser are with 2 passes and 1.0MPa design water-side pressure.
- Carrier will select specific models using E-Cat on different requests for tonnage, lift, and efficiency. For details, please contact local agencies.
- Standard evaporator and condenser water-side pressure is 1.0MPa. For more requirements, please contact local agencies.
- For more details or customized selections, please contact local agencies.



Certified in accordance with the AHRI Water-Cooled Water-Chilling and Heat Pump Water-Heating Packages. Certification Program, which is based on AHRI Standard 550/590 (I-P) and AHRI Standard 551/591 (SI). Certified units may be found in the AHRI Directory at www.ahndirectory.org

<http://www.ahridirectory.org>

19DV Chiller Dimensions

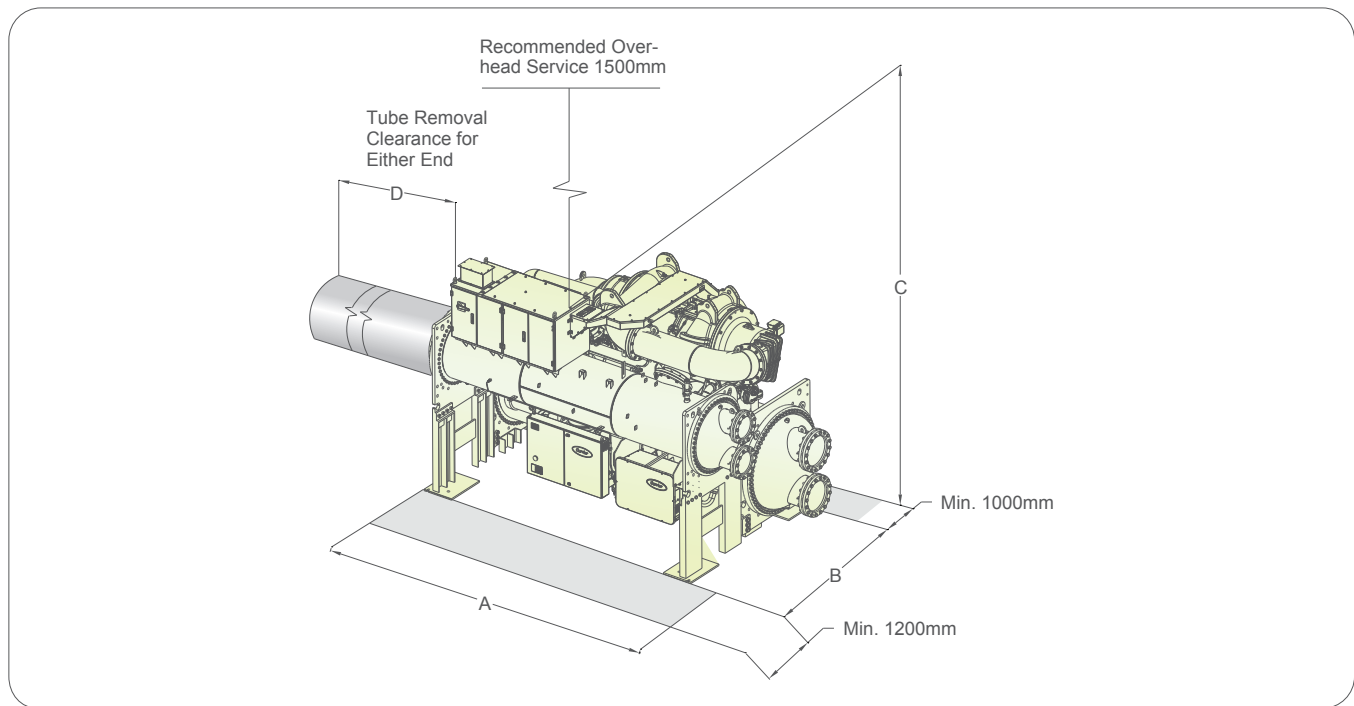

Evaporator Size	Condenser Size	A-Length with NIH waterbox (2-Pass) mm	B-Width mm	C-Height mm	D-Tube Removal Space for Either End mm
F2A-F29	F2C-F29	4596	2469	2852	4267
F4A-F49	F4C-F49	5116	2469	2852	4877
G2A-G29	G2C-G29	4680	2629	3058	4267
G4A-G49	G4C-G49	5201	2629	3058	4877
H2A-H29	H2C-H29	4686	2832	3229	4267
H4A-H49	H4C-H49	5206	2832	3229	4877

Field Wiring Specifications (with VFD)

I. General

- 1.0 All field-supplied conductors, devices and the field-installation wiring, termination of conductors and devices must be in compliance with all applicable codes and job specifications.
- 1.1 The routing of field-installed conduit and conductors and location of field-installed devices must not interfere with equipment access or the reading, adjusting or servicing of any component.
- 1.2 Equipment installation and all starting and control devices must comply with details in equipment submittal drawings and literature.
- 1.3 Contacts and switches are shown in the position, which would de-energize the circuit and cause chiller shut down.
- 1.4 **WARNING-**Do not use aluminum conductors.

II. Power Wiring to VFD Starter

- 2.0 Provide a means of disconnecting power to starter. Fused disconnect is required on VFD.
- 2.1 Incoming power wire must be protected with metal jacket.
- 2.2 Line side power conductor rating must meet VFD nameplate voltage and chiller full load amps (minimum circuit ampacity).
- 2.3 VFD and controls must be grounded by using equipment grounding lugs provided inside unit mounted starter enclosure.

Typical Piping and Wiring Unit Mounted VFD (Standard Tier)

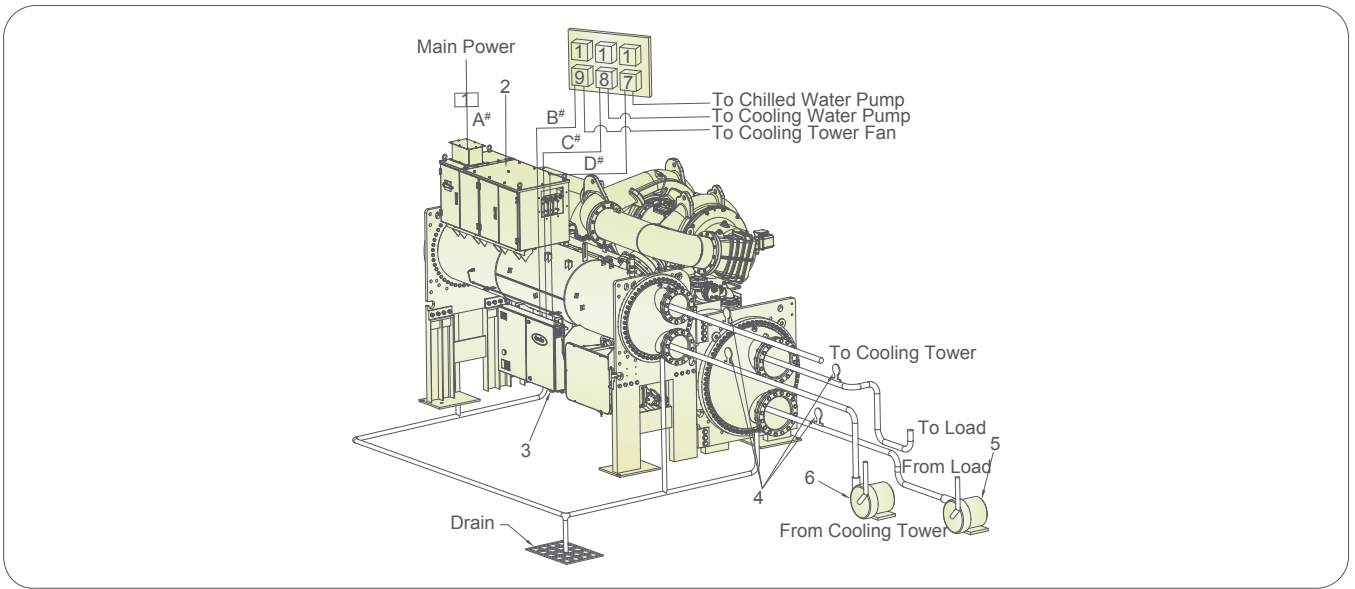

Typical Piping and Wiring Unit Mounted VFD (High Tier)

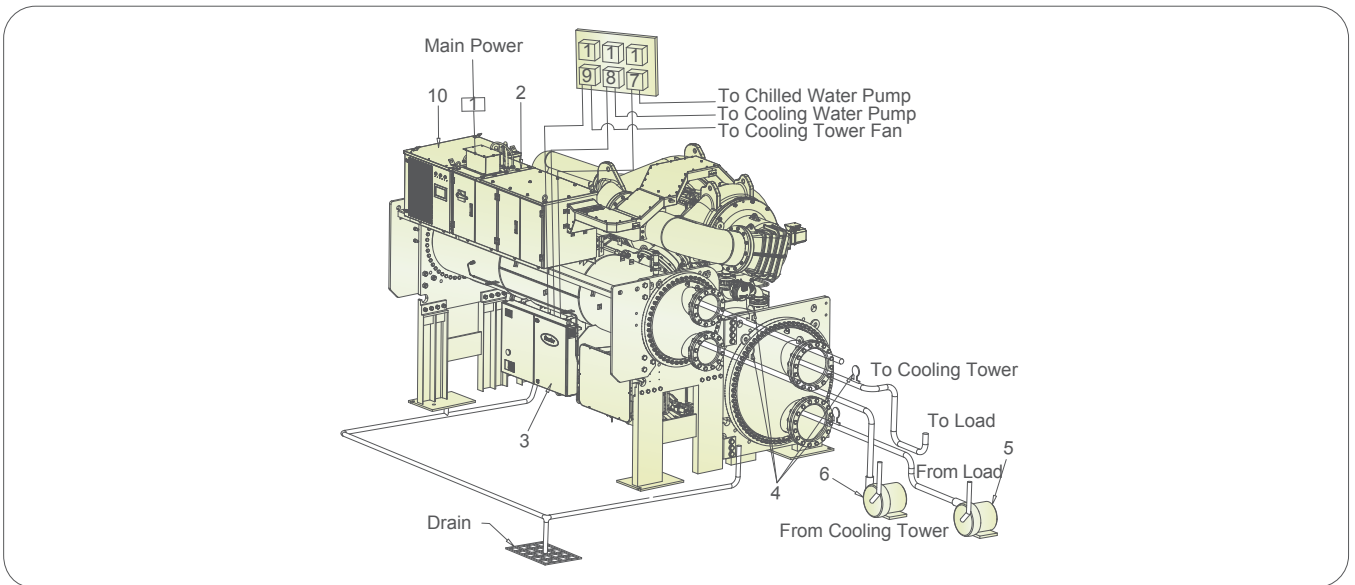

- | | | | |
|---|--|---|-------------------|
| ① Air switch (NOT by Carrier) | ② VFD | ③ Control box | ④ Pressure gauges |
| ⑤ Chilled water pump | ⑥ Cooling water pump | ⑦ Chilled water pump starter (NOT by Carrier) | |
| ⑧ Cooling water pump starter (NOT by Carrier) | ⑨ Cooling tower fan starter (NOT by Carrier) | ⑩ AHF | |

Line Purpose

- A# Main power to VFD
 B# To cooling tower fan starter (option)
 C# To cooling water pump starter (option)
 D# To chilled water pump starter (option)

Specification

- 50Hz or 60Hz low voltage AC power source: 3 phase, 1 grounding
 4 control lines (option)
 2 control lines (option)
 2 control lines (option)

Piping and Wiring Requirements:

- The installer must get all pipes and wires in place and mark the ends.
- Filters must be installed in cooling water and chilled water pipes.
- Thermometer (0-50°C) and pressure gauge (0~1Mpa or 2MPa) must be installed at inlet and outlet of the pipes.
- The installer must install the relief valve vent to outdoors with a steel pipe(outer diameter 48mm, thickness 4mm).
- It is suggested that an oxygen content monitor be installed in the machine room for safety, which will give an alarm when the oxygen content is less than 19.5%.
- Input power shall be in compliance with Carrier applicable codes and job specifications. For more details or customized conditions, please contact local agencies.

Types of Base Isolation

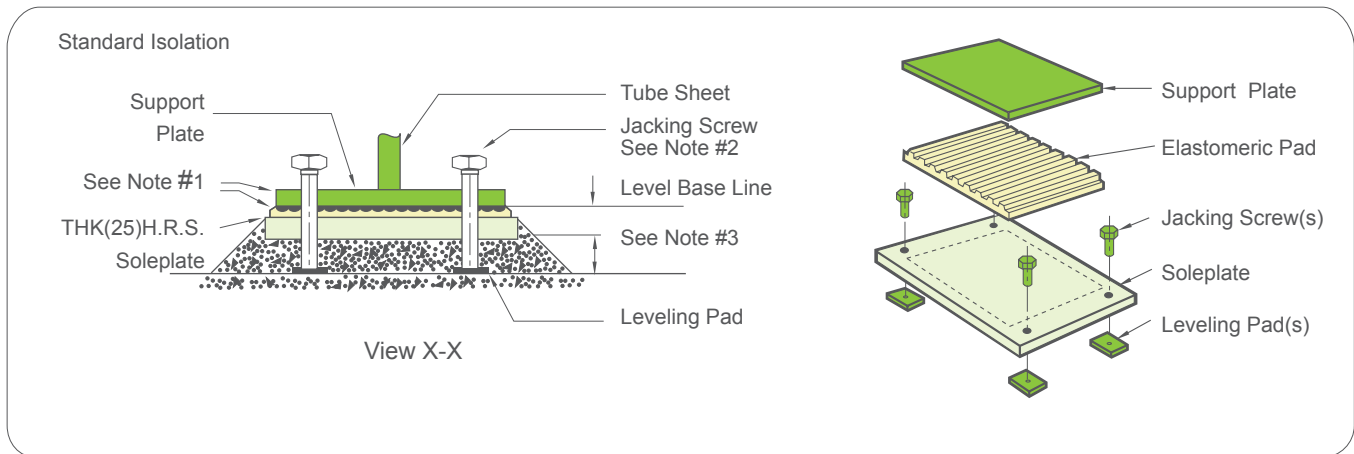
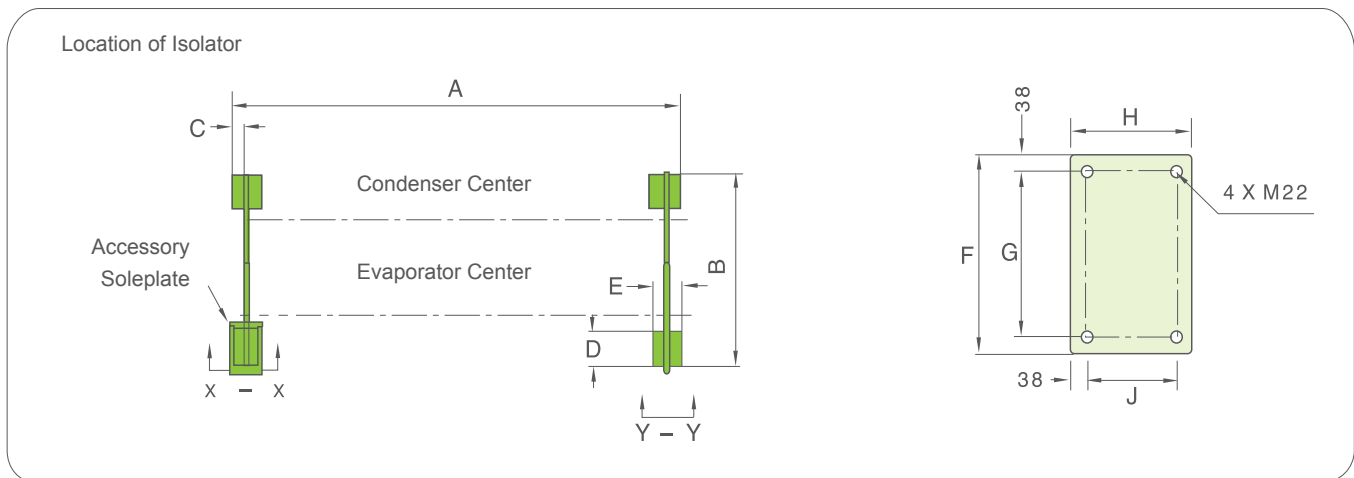

Notes:

1. Accessory soleplate package includes 4 soleplates, 16 jacking screws, and 16 leveling pads.
2. Jacking Screws should be removed after the grout has set.
3. Thickness of grout varies, depending on the amount necessary to level chiller.

Evaporator/Condenser Size	A mm	B mm	C mm	D mm	E mm	F mm	G mm	H mm	J mm
F2A-F29/F2C-F29	3951	2260	102	559	406	711	635	432	356
F4A-F49/F4C-F49	4472	2260	102	559	406	711	635	432	356
G2A-G29/G2C-G29	3951	2508	102	559	406	711	635	432	356
G4A-G49/G4C-G49	4472	2508	102	559	406	711	635	432	356
H2A-H29/H2C-H29	3951	2612	102	559	406	711	635	432	356
H4A-H49/H4C-H49	4472	2612	102	559	406	711	635	432	356



Carrier improves the world around us; Carrier improves people's lives; our products and services improve building performance; our culture of improvement will not allow us to rest when it comes to the environment.



www.carrier.com

The Manufacturer reserves the right to change any product specifications without prior notices
© All Rights Reserved Carrier

Version:	CAT-AQUAEDGE-19DV_202006_05
Supersede:	CAT-AQUAEDGE19DV_1910_04
Effective Date:	June, 2020