



**AQUAFORCE<sup>®</sup>**

# 30KA Air-Cooled Liquid Chiller

Nominal cooling capacity: 336~1484kW





Carrier is a leading global provider of innovative HVAC, refrigeration, fire, security and building automation technologies. Supported by the iconic Carrier name, the company's portfolio includes industry-leading brands such as Carrier, Kidde, Edwards, LenelS2 and Automated Logic. Carrier's businesses enable modern life, delivering efficiency, safety, security, comfort, productivity and sustainability across a wide

range of residential, commercial and industrial applications.

In 1998, Time magazine named Dr. Carrier one of its 20 most influential builders and titans of the 20th century.



## Nomenclature

30KA1050

A

PT002B

○	PT001	Cu/Cu coil
	PT002B	Blygold PoluAL
	PT003A	Pretreated golden fins
	PT012	High Static Fan
	PT015A	low noise (single layer sound jacket)
	PT015S	low noise (dual layer sound jacket)
	PT020A	IP54 control box
	PT028	Winter operation
	PT041A	evaporator frost protection
	PT041B	Evap.and hydr. frost protection must be selected with PT116B or PT116C
	PT071	high efficiency
	PT093A	compressor discharge valve
	PT104	1.6Mpa evaporator
	PT107	1300/1350/1400/1500 not available
	PT116B	350/450/500 351/451/501
	PT116C	350/450/500 351/451/501
	PT148B	CCN to J-Bus gateway
	PT148C	CCN to BACnet MSTP gateway
	PT148D	CCN to LonTalk gateway
	PT156	Energy Management Module
	PT158A	7" Carrier SmartView™ touch screen
	PT275	remote controller
	PT281	Evaporator Aluminum Jacket
	PT299	38mm Evaporator insulation
	PT301	lead/lag control
	PT303	anti-corrosion option blue fine
	PT305A	Spring Isolator
	PT309	Isolate valve for safety valve
	PT309D	Isolate valve for safety valve (dual safety valve)
	PT312A	Australian Code
	PT842	AMSE Code

○ Design Series

○ Unit Model Air-cooled Screw chiller 30KA0550-1350

## Operating Range

Evaporator		Min. temperature	Max. temperature
Entering water temperature (at start)	°C	-	45
Entering water temperature (operating)	°C	6.8	21
Leaving water temperature (operating)	°C	3.3	15
Condenser		Min. temperature	Max. temperature
Outdoor air temperature	°C	-10*	50

\* With PT028 "winter operation", outdoor air temperature may down to -20°C. A glycol/water solution or evaporator antifreeze.

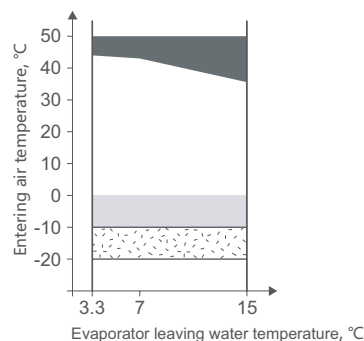

- Operating range, unit equipped with option PT028 (winter operation).
- Below 0°C air temperature the unit must either be equipped with the evaporator frost protection option (PT041A), or the water loop must be protected against frost by using a frost protection solution (by the installer).
- Part load average.

## Features

- ✔ 30KA the premium solution for industrial and commercial applications where installers, consultants and building owners require optimal performances and maximum quality.

## Benefits

- ✔ Extremely high full load and part load energy efficiency leads to extremely low operation cost, customer even select high efficiency option(PT071) to achieve higher performance and more energy saving.
- ✔ Low operating sound with no intrusive low-frequency noise, creates a better working/living environment.
- ✔ Environmentally sound refrigerant HFC-134a of zero ozone depletion potential.
- ✔ Easy and fast installation to reduce on-site installation time.
- ✔ Exceptional endurance tests ensure superior reliability to minimize chiller down-time.

## Economical operation

- ✔ Extremely high full load and part load energy efficiency:
  - Twin-rotor screw compressor equipped with a high efficiency motor and a variable capacity valve that permits exact matching of the cooling capacity to the load.
  - Flooded multi-pipe evaporator to increase the heat exchange efficiency, configured with aluminium cladding (standard) to improve thermal insulation and prevent energy loss.
  - Electronic expansion device allows operation at a lower condensing pressure and improved utilization of the evaporator heat exchange surface (superheat control).
  - Economizer system with electronic expansion device permits a considerable increase in cooling capacity and contributes to optimised energy efficiency of the chiller installation.
- 30KA AHRI certificate

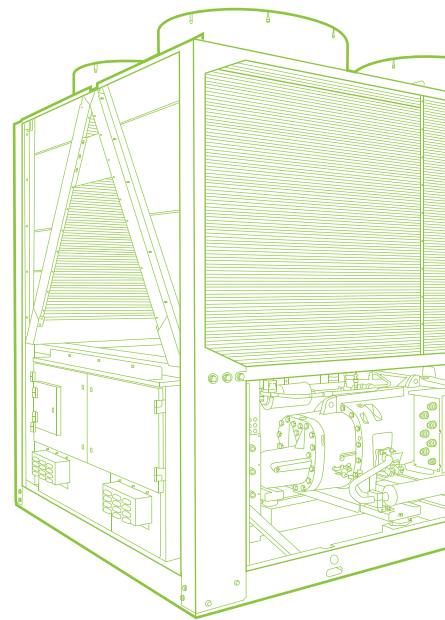

## Quiet operation

- Compressors
  - Discharge dampers integrated in the oil separator.
  - Acoustic compressor and oil separator enclosures (option) reduce the radiated noise.
- Condenser section
  - Condenser coils in W-shape with an open angle, allows quieter air flow across the coil.
  - VI Low-noise Flying Bird fans enjoy quieter operation and never generate intrusive low-frequency noise.



Twin screw CARRIER compressor

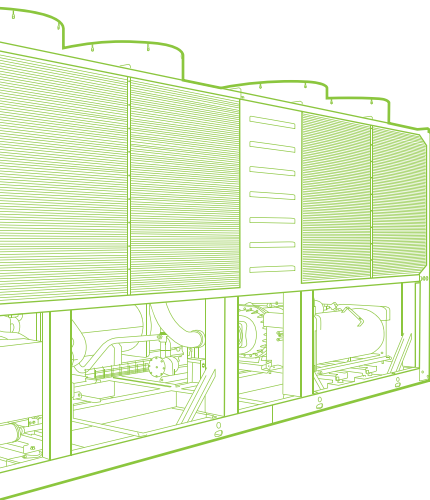

## Environmental Friendly

- HFC-134a refrigerant
  - Refrigerant of the HFC group with zero ozone depletion potential.
- Leak-tight refrigerant circuit
  - Reduction of leaks as no capillary tubes and flare connections are used.
  - Verification of pressure transducers and temperature sensors without transferring refrigerant charge.



## Absolute reliability

- Screw compressors
  - Industrial-type screw compressors with oversized bearings and motor cooled by suction gas.
  - All compressor components are easily accessible on site minimizing down-time.
  - Electronic motor protection against overloads and power supply faults (loss of phase, phase reversal).
- Evaporator
  - Thermal insulation with aluminium cladding for perfect resistance against outside aggression (mechanical and UV protection).
- Exceptional endurance tests:
  - Partnerships with specialised laboratories and use of limit simulation tools (finite element calculation) for the design of critical components.
  - Transport simulation test equivalent to 2000 km by truck under harsh conditions.
  - Salt mist corrosion resistance test in the laboratory for increased corrosion resistance.

**CERTIFIED**<sup>®</sup>  
www.ahridirectory.org

and 551/591

## General Features

### 🌿 New innovative smart control features:

- An intuitive and user-friendly, 4.3" colored interface (7" as option).
- Screen-shots with concise and clear information in local languages.
- Complete menu, customized for different users (end user, service personnel and Carrier-factory technicians).
- Easy access to the controller box with touch screen mounting to ensure legibility under any lighting conditions.
- Safe operation and unit setting: password protection ensures that unauthorized people cannot modify any advanced parameters.
- Simple and "smart" intelligence uses data collection from the constant monitoring of all machine parameters to optimise unit operation.
- Night-mode: Cooling capacity management for reduced noise level.

## Economical operation

### 🌿 Energy management:

- Internal time schedule clock controls chiller on/off times and operation at a second set-point.
- The DCT (Data Collection Tool) records the alarms history to simplify and facilitate service operations.

## Remote Management (Standard)

- Units with SmartView™ control can be easily accessed from the internet, using a PC with an Ethernet connection. This makes remote control quick and easy and offers significant advantages for service operations.
- Equipped with an RS485 serial port that offers multiple remote control, monitoring and diagnostic possibilities. When networked with other Carrier equipment through the CCN (Carrier Comfort Network - proprietary protocol), all components form a HVAC system fully-integrated and balanced through one of the Carrier's network system products, like the Chiller System Manager or the Plant System Manager (optional).

SmartView™ control panel supports CCN, BACnet IP, Modbus TCP/IP and Modbus RTU protocols, with which chiller can seamlessly connect with the BMS or the i-Vu®/WebCTRL control network. Moreover, Lonwalk, J-Bus and BACnet MSTP is also supported with optional gateway.



Large colored

## Quiet operation

- ✦ The following commands/visualizations are possible from remote
  - Start/Stop of the machine.
  - Dual set-point management: Through a dedicated contact is possible to activate a second set-point (example: unoccupied mode).
  - Demand limit setting: To limit the maximum chiller capacity to a predefined value.
  - Water pump control: These outputs control the contactors of one/two evaporator water pumps.
  - Operation visualization: Indication if the unit is operating or if it's in stand-by (no cooling load).
  - Alarm visualization.

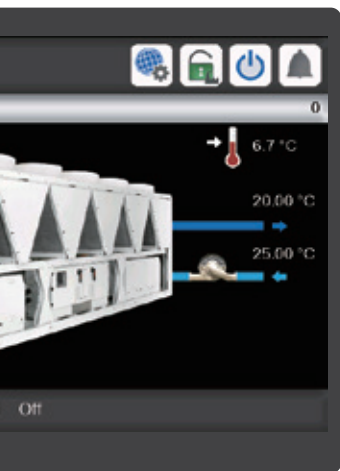

touch display

## Absolute reliability

- ✦ The Energy Management Module (EMM) offers extended remote control possibilities:
  - Room temperature: Permits set-point reset based on the building indoor air temperature (if Carrier thermostat are installed).
  - Set-point reset: Ensures reset of the cooling set-point based on a 4-20 mA or 0-10 V signal.
  - Demand limit: Permits limitation of the maximum chiller power or current based on 0-10 V signal.
  - Demand limit 1 and 2: Closing of these contacts limits the maximum chiller power or current to two predefined values.
  - User safety: This contact can be used for any customer safety loop; opening the contact generates a specific alarm.
  - Ice storage end: When ice storage has finished, this input permits return to the second set-point (unoccupied mode).
  - Time schedule override: Closing of this contact cancels the time schedule effects.
  - Out of service: This signal indicates that the chiller is completely out of service.
  - Chiller capacity: This analogue output (0-10 V) gives an immediate indication of the chiller capacity.
  - Alert indication: This volt-free contact indicates the necessity to carry out a maintenance operation or the presence of a minor fault.
  - Compressors running status : Set of outputs (as many as the compressors number) indicating which compressors are running.

## Performance data

Model	30KA	0350A	0450A	0500A	0550A	0700A	0750A	0800A	0900A	1000A	1050A	1100A
Nominal cooling capacity*	kW	336.0	426.0	500.0	560.0	668.1	722.0	774.0	890.0	990.0	1076	1120
Compressor power input	kW	99.4	125.7	151.7	171.2	192.8	220.6	238.3	269.6	297.0	331.4	349.3
Total power input	kW	105.6	134.7	160.7	183.0	207.4	235.2	252.9	287.0	317.2	351.6	369.5
Nominal COP	kW/kW	3.182	3.162	3.111	3.060	3.221	3.070	3.060	3.101	3.121	3.060	3.032
IPLV.IP**	kW/kW	4.500	4.495	4.502	4.439	4.615	4.603	4.449	4.418	4.447	4.471	4.424
Compressor		Semi-hermetic screw compressor										
CircuitA		1	1	1	1	1	1	1	1	1	1	1
CircuitB		1	1	1	1	1	1	1	1	1	1	1
Minimum capacity	%	15%	15%	15%	15%	15%	15%	15%	15%	15%	15%	15%
Refrigerant		R134a										
CircuitA	kg	64	85	85	85	100	114	114	110	140	175	175
CircuitB	kg	64	70	80	80	95	97	100	110	129	107	111
Control		Carrier SmartView™										
Condenser		Cu/Al heat exchanger										
Fans		VI generation FlyingBird axial fan										
Quantity		4	6	6	8	10	10	10	12	14	14	14
Total air flow	l/s	20042	30063	30063	40084	50105	50105	50105	60127	70148	70148	70148
Fan speed	rpm	950										
Evaporator		Flooded multi-pipe										
Water content	l	54	63	69	78	93	99	117	127	157	174	174
Nominal water flow	l/s	16.02	20.31	23.83	26.69	31.85	34.41	36.89	42.42	47.19	51.29	53.39
Nominal water pressure drop	kPa	19.5	37.8	40.0	55.1	45.7	45.6	45.6	48.4	44.6	47.8	51.4
Max. water-side pressure (without hydronic module)	kPa	1000										
Integrated hydronic module (option)		Pump, safety valve, expansion tank etc.										
Water pump		Centrifugal pump										
Water head external to chiller (single pump at nominal water flow rate)	kPa	169.6	253.2	201.5	-	-	-	-	-	-	-	-
Expansion tank	l	80	80	80	-	-	-	-	-	-	-	-
Max. water-side pressure (with hydronic module)	kPa	400	400	400	-	-	-	-	-	-	-	-
Water connection		Victaulic										
Nominal Diameter	DN	125	125	125	125	150	150	150	150	200	200	200
Electrical data												
Nominal power supply		400V-3Ph-50Hz										
Control power supply		Star-delta start										
Start-up method		24V via internal transformer										
Fan and control power	kW	6.2	9.0	9.0	11.8	14.6	14.6	14.6	17.4	20.2	20.2	20.2
Nominal unit current draw,	A	177.2	226.1	269.8	307.0	348.0	395.0	425.0	483.0	533.0	590.0	620.0
Maximum unit current draw	A	225.7	295.4	324.2	365.0	429.0	482.0	511.0	600.0	695.0	719.0	763.0
Maximum start-up current	A	295.4	513.4	513.4	591.0	627.0	790.0	822.0	920.0	973.0	1053.0	1053.0
Max operation power	kW	138	180	198	223	262	294	312	366	424	438	465
Unit length	mm	3715	4801	4801	4801	6126	6298	6298	7410	8410	8410	8410
Unit width	mm	2253										
Unit height	mm	2379										
Shipping weight	kg	3556	4562	4641	4696	5388	5731	5828	6473	7088	7627	7991
Operating weight (Standard)	kg	3410	4425	4510	4595	5224	5561	5658	6298	6927	7466	7830

### Notes:

\* Nominal conditions - evaporator entering/leaving water temperature=12/7°C, outdoor air temperature = 35°C  
Evaporator fouling factor = 0.018m<sup>2</sup>/kW

\*\* IPLV Calculations according to standard performances (in accordance with AHRI 550-590)



## Performance data

Model	30KA	1250A	1300A	1350A	1400A	1500A	0351A	0451A	0501A	0651A	0701A	0751A
Nominal cooling capacity*	kW	1227	1317	1393	1435	1484	340.0	442.0	487.0	617.0	679.0	751.0
Compressor power input	kW	377.9	400.4	419.0	429.5	452.5	92.7	133.4	150.1	194.3	199.1	231.5
Total power input	kW	400.9	423.4	444.8	455.3	478.3	101.7	142.4	159.1	206.1	213.7	246.1
Nominal COP	kW/kW	3.060	3.111	3.132	3.152	3.103	3.342	3.103	3.061	2.993	3.177	3.051
IPLV.IP**	kW/kW	4.505	4.495	4.565	4.494	4.483	4.486	4.477	4.406	4.406	4.458	4.415
Compressor		Semi-hermetic screw compressor										
CircuitA		1	1	1	1	1	1	1	1	1	1	1
CircuitB		1	1	1	1	1	-	-	-	-	-	-
Minimum capacity	%	15%	15%	15%	15%	15%	30%	30%	30%	30%	30%	30%
Refrigerant		R134a										
CircuitA	kg	190	180	195	190	190	100	110	115	175	180	190
CircuitB	kg	111	175	170	180	190	-	-	-	-	-	-
Control		Carrier SmartView™										
Condenser		Cu/Al heat exchanger										
Fans		VI generation FlyingBird axial fan										
Quantity		16	16	18	18	18	6	6	6	8	10	10
Total air flow	l/s	80169	80169	90190	90190	90190	30063	30063	30063	40084	50105	50105
Fan speed	rpm	950										
Evaporator		Flooded multi-pipe										
Water content	l	174	202	202	208	208	44	84	84	101	101	101
Nominal water flow	l/s	58.49	62.79	66.41	68.41	70.75	16.21	21.07	23.21	29.41	32.37	35.80
Nominal water pressure drop	kPa	60.7	40.5	44.9	47.4	50.4	32.6	35.1	42.7	41.8	50.2	60.9
Max. water-side pressure (without hydronic module)	kPa	1000										
Integrated hydronic module (option)		Pump, safety valve, expansion tank etc.										
Water pump		Centrifugal pump										
Water head external to chiller (single pump at nominal water flow rate)	kPa	-	-	-	-	-	154.4	247.0	207.6	-	-	-
Expansion tank	l	-	-	-	-	-	80	80	80	-	-	-
Max. water-side pressure (with hydronic module)	kPa	-	-	-	-	-	400	400	400	-	-	-
Water connection		Victaulic										
Nominal Diameter	DN	200	150	150	150	150	125	125	125	150	150	150
Electrical data												
Nominal power supply		400V-3Ph-50Hz										
Control power supply		Star-delta start										
Start-up method		24V via internal transformer										
Fan and control power	kW	23.0	23.0	25.8	25.8	25.8	9.0	9.0	9.0	11.8	14.6	14.6
Nominal unit current draw,	A	672.0	710.5	743.0	764.1	802.7	170.8	239.1	267.0	346.0	358.7	413.1
Maximum unit current draw	A	822.0	864.2	897.0	923.0	949.1	218.0	317.9	344.0	419.0	451.8	477.9
Maximum start-up current	A	1118.0	1124.0	1160.0	1160.0	1160.0	388.0	587.0	587.0	629.0	629.0	629.0
Max operation power	kW	501	527	547	563	579	133	194	210	255	275	291
Unit length	mm	9509	9486	10584	10584	10584	3668	3668	3668	4751	5831	5831
Unit width	mm	2253										
Unit height	mm	2379										
Shipping weight	kg	8121	9489	9345	9893	9912	3268	3784	3794	4907	5348	5358
Operating weight (Standard)	kg	7925	9293	9117	9699	9718	3112	3668	3678	4808	5186	5196

### Notes:

\* Nominal conditions - evaporator entering/leaving water temperature=12/7°C, outdoor air temperature = 35°C

Evaporator fouling factor = 0.018m<sup>2</sup>/kW

\*\* IPLV Calculations according to standard performances (in accordance with AHRI 550-590)

# Dimension Drawing

30KA0350A

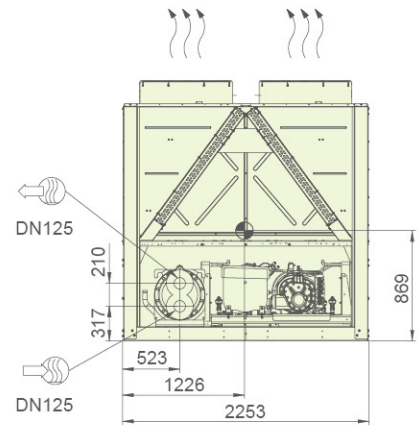
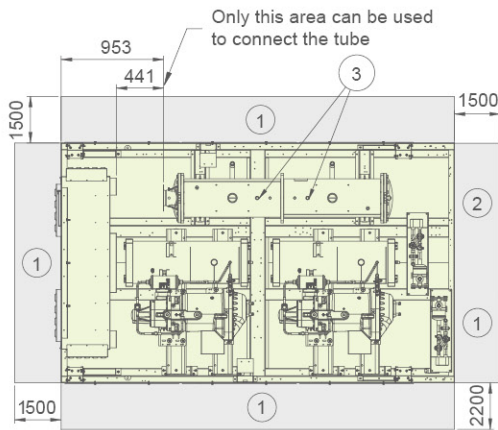
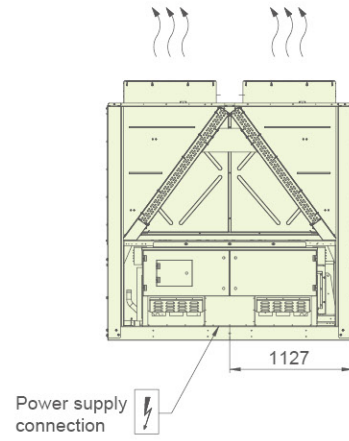
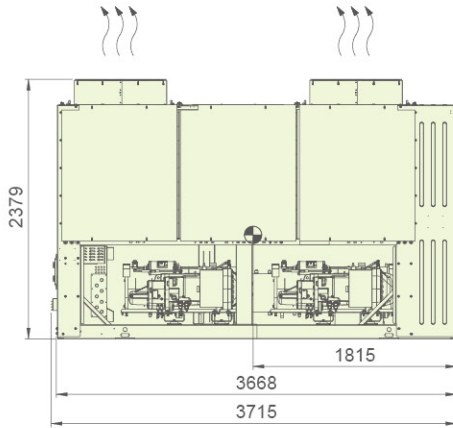

- ① Required clearances for maintenance
- ② Recommended space for evaporator tube removal
- ③ Safety valve
- Water inlet
- Water outlet
- Air outlet
- Power supply connection
- Center gravity

# Dimension Drawing

30KA0350APT116B

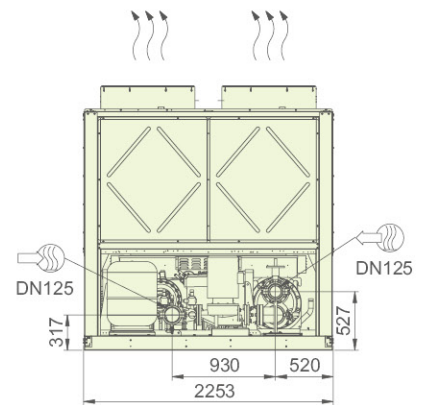
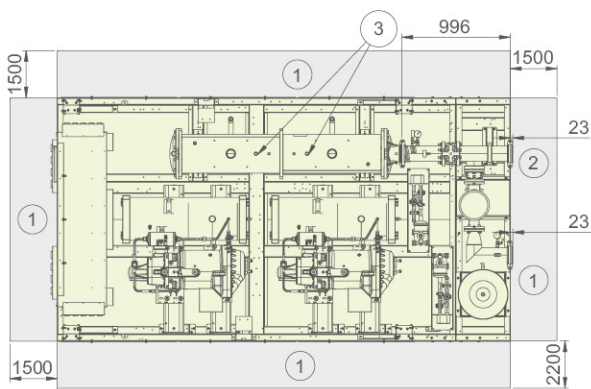
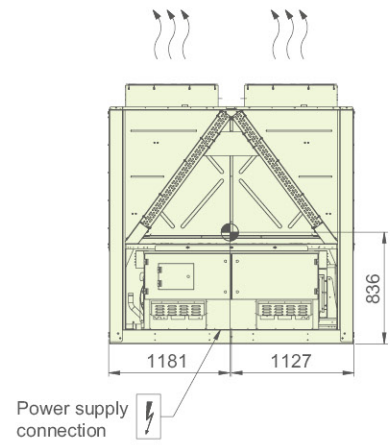
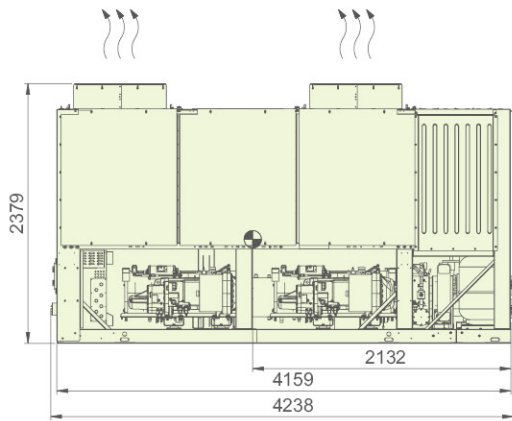

- ① Required clearances for maintenance
- ② Recommended space for evaporator tube removal
- ③ Safety valve
- Water inlet
- Water outlet
- Air outlet
- Power supply connection
- Center gravity

# Dimension Drawing

30KA0350APT116C

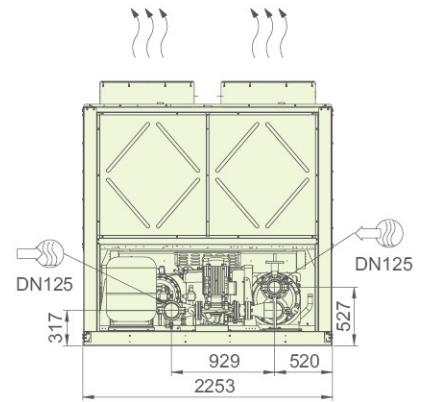
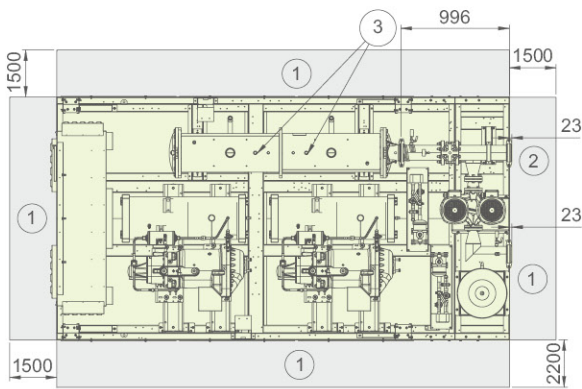
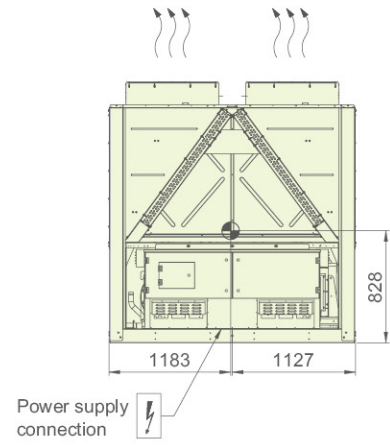
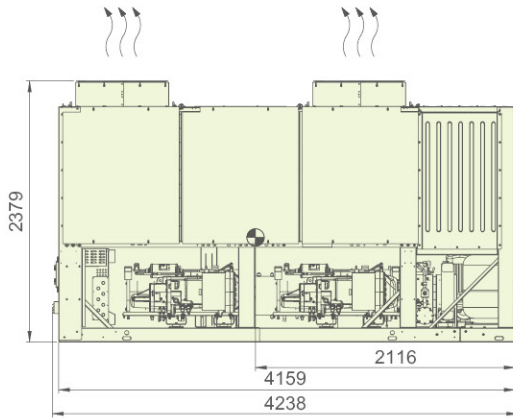

- ① Required clearances for maintenance
- ② Recommended space for evaporator tube removal
- ③ Safety valve
- Water inlet

- Water outlet
- Air outlet
- Power supply connection
- Center gravity

# Dimension Drawing

30KA0351A

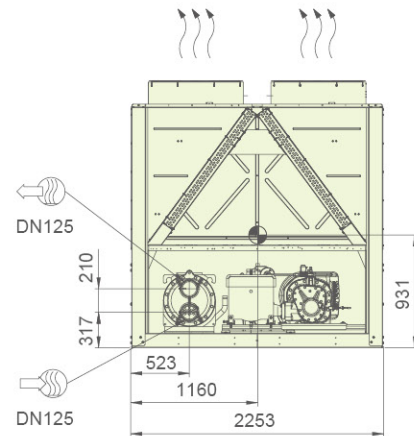
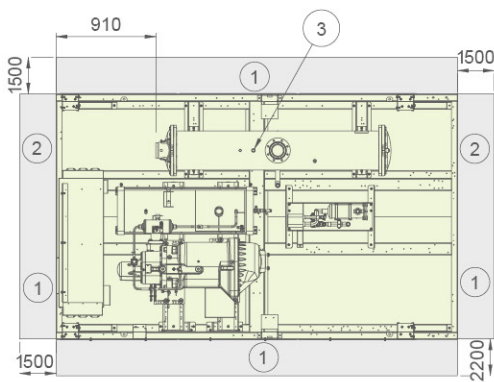
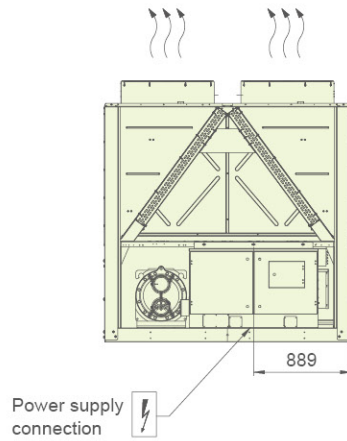
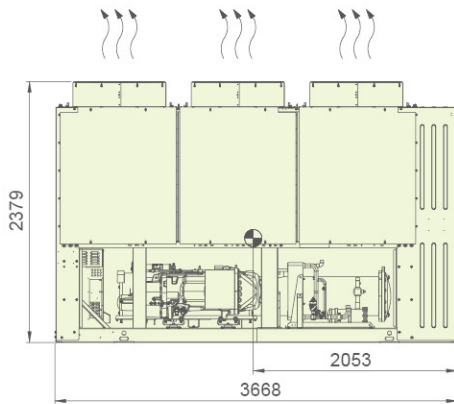

- ① Required clearances for maintenance
- ② Recommended space for evaporator tube removal
- ③ Safety valve
- Water inlet

- Water outlet
- Air outlet
- Power supply connection
- Center gravity

# Dimension Drawing

30KA0351APT116B

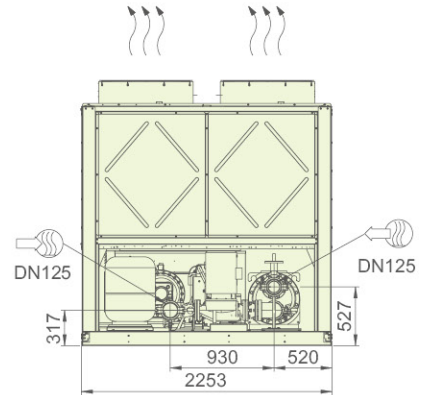
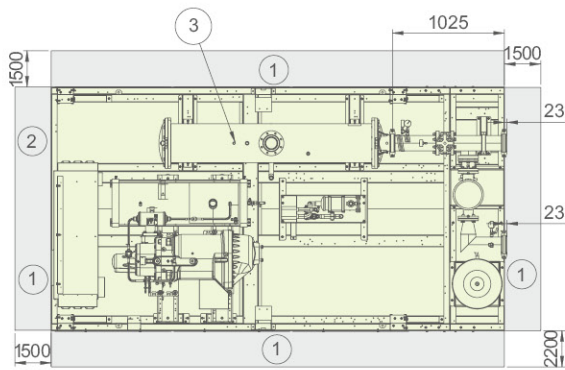
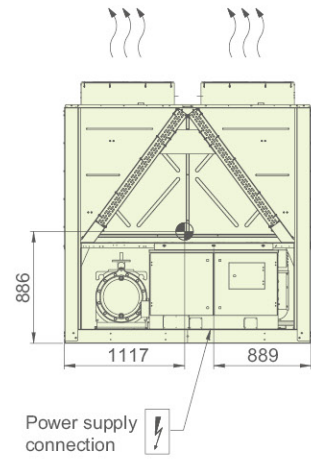
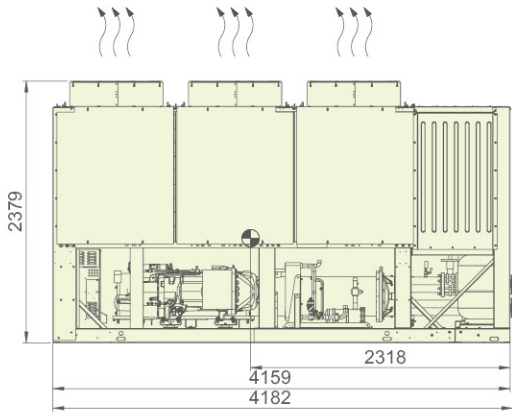

- ① Required clearances for maintenance
- ② Recommended space for evaporator tube removal
- ③ Safety valve
- Water inlet
- Water outlet
- Air outlet
- Power supply connection
- Center gravity

# Dimension Drawing

30KA0351APT116C

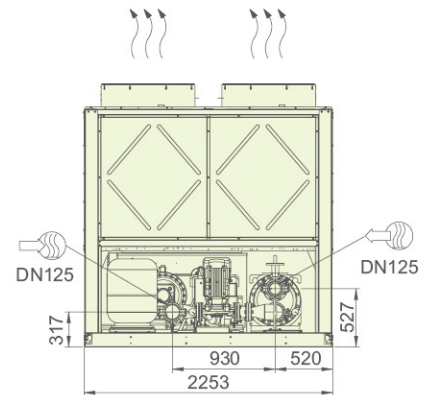
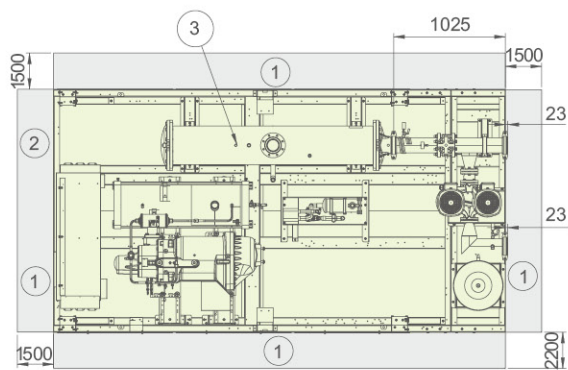
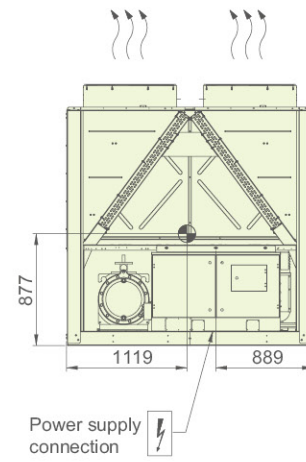
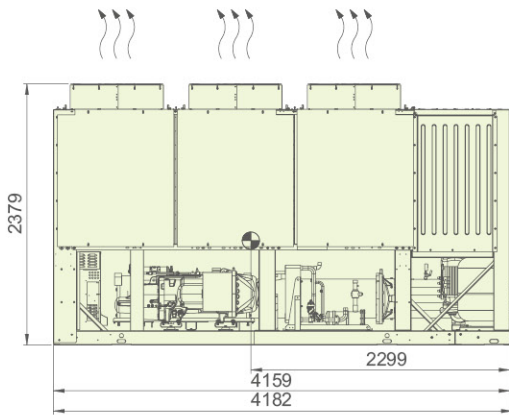

- ① Required clearances for maintenance
- ② Recommended space for evaporator tube removal
- ③ Safety valve
- Water inlet
- Water outlet
- Air outlet
- Power supply connection
- Center gravity

# Dimension Drawing

30KA0450A-0500A

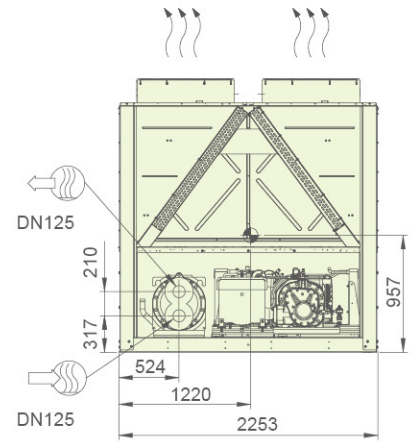
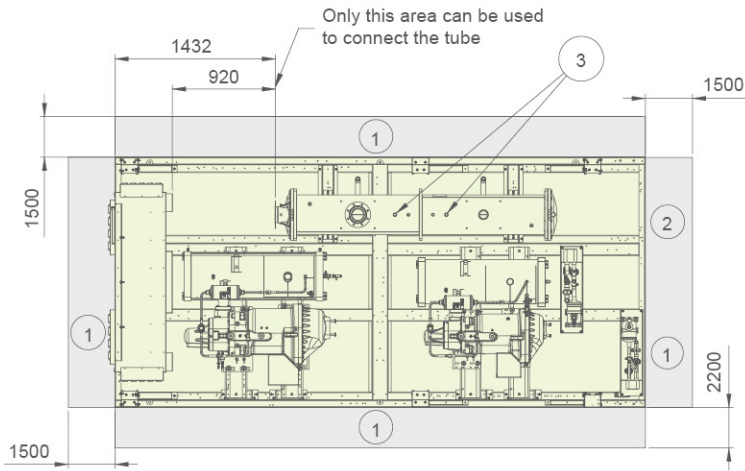
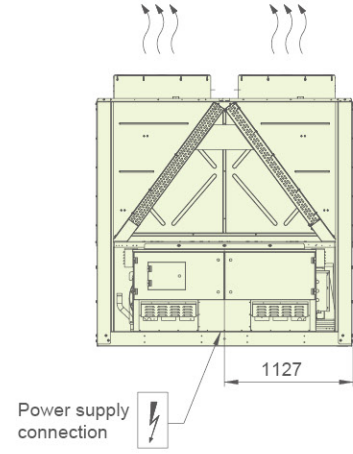
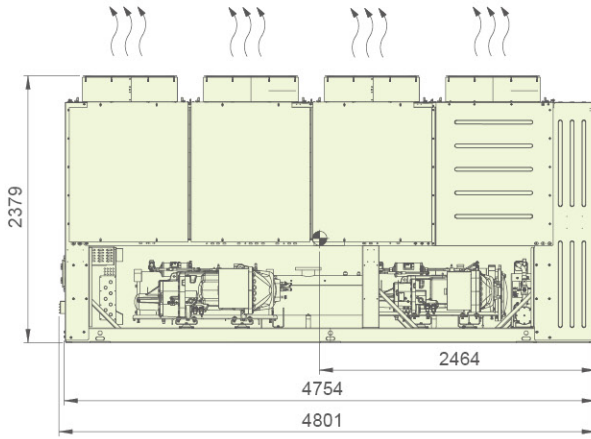

- ① Required clearances for maintenance
- ② Recommended space for evaporator tube removal
- ③ Safety valve
- Water inlet
- Water outlet
- Air outlet
- Power supply connection
- Center gravity



# Dimension Drawing

30KA0450A-0500APT116B

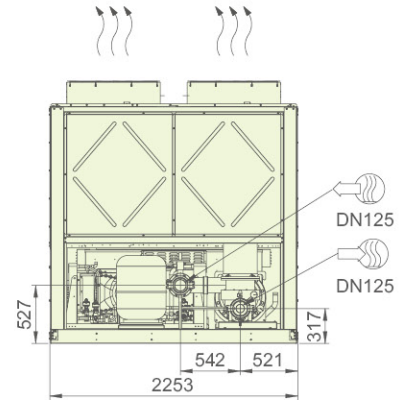
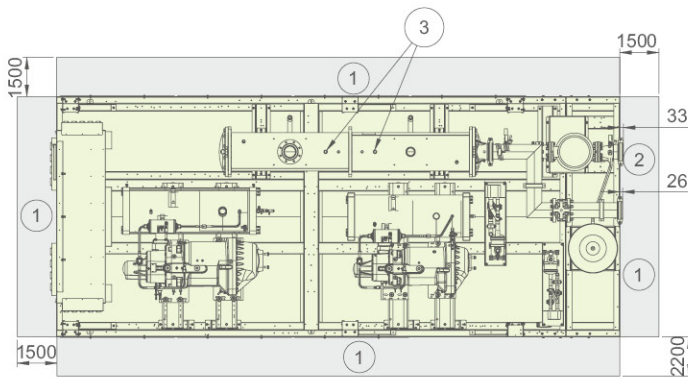
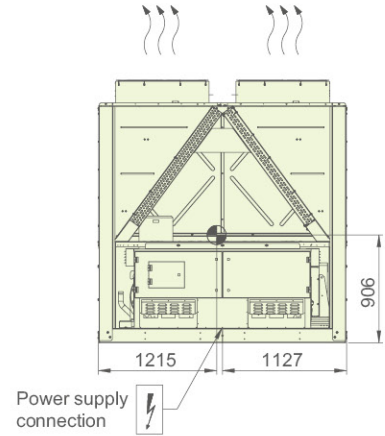
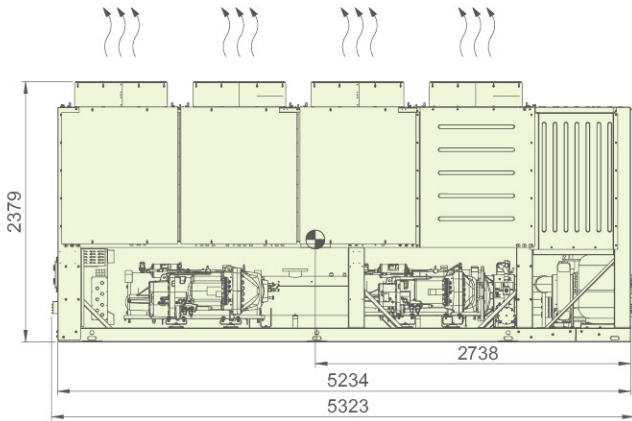



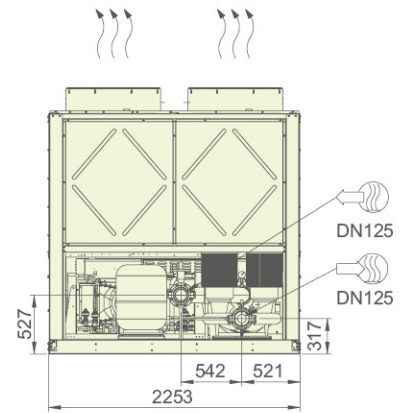
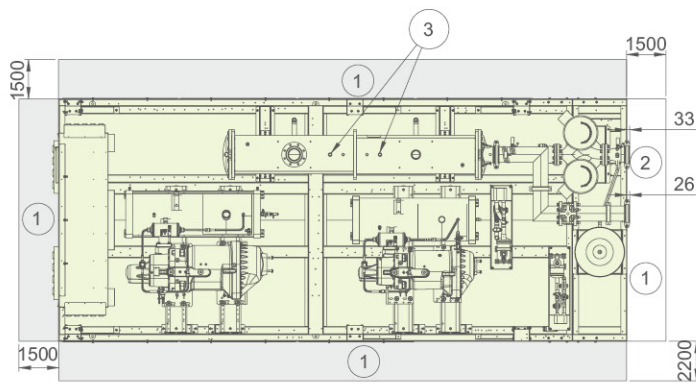
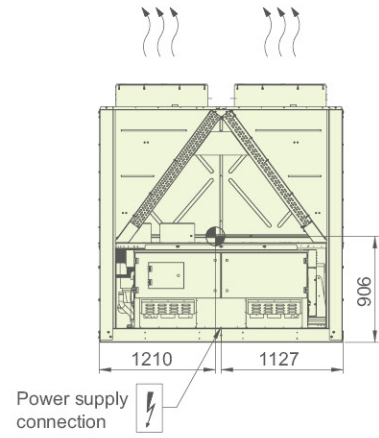
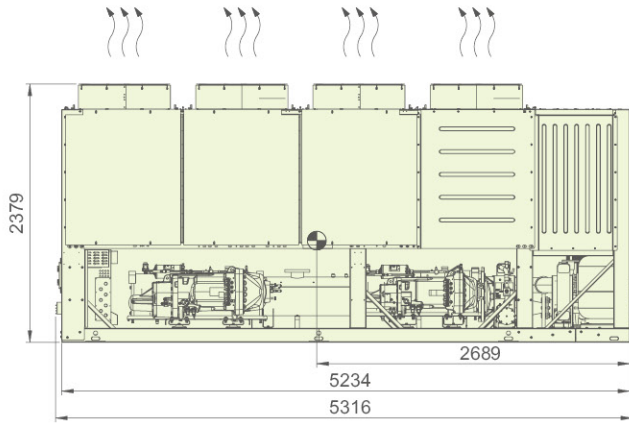

- ① Required clearances for maintenance
- ② Recommended space for evaporator tube removal
- ③ Safety valve
- Water inlet
- Water outlet
- Air outlet
- Power supply connection
- Center gravity

# Dimension Drawing

30KA0450A-0500APT116C

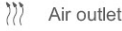

- ① Required clearances for maintenance
- ② Recommended space for evaporator tube removal
- ③ Safety valve
-  Water inlet
-  Water outlet
-  Air outlet
-  Power supply connection
-  Center gravity

# Dimension Drawing



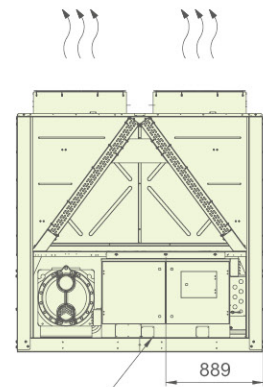
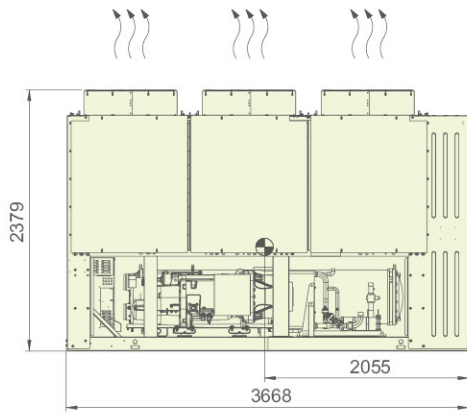

30KA0451A-0501A

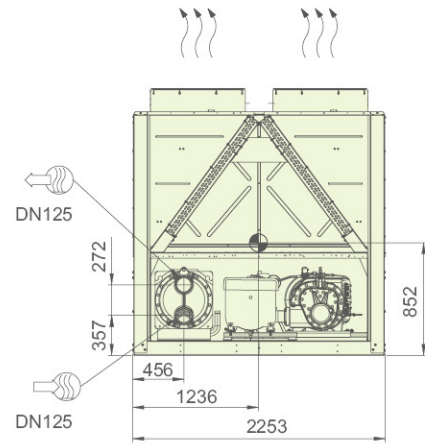
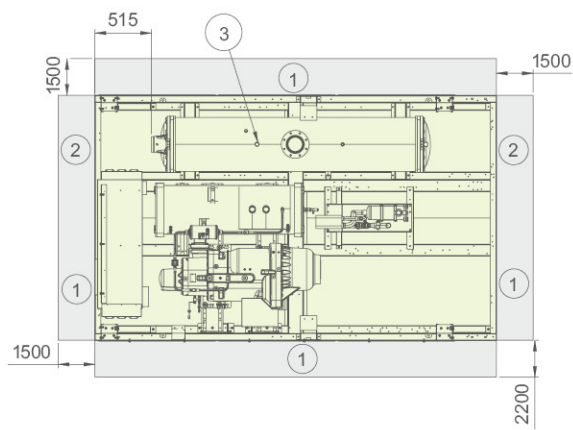

Power supply connection 



- ① Required clearances for maintenance
- ② Recommended space for evaporator tube removal
- ③ Safety valve
-  Water inlet

-  Water outlet
-  Air outlet
-  Power supply connection
-  Center gravity

# Dimension Drawing

30KA0451A-0501APT116B

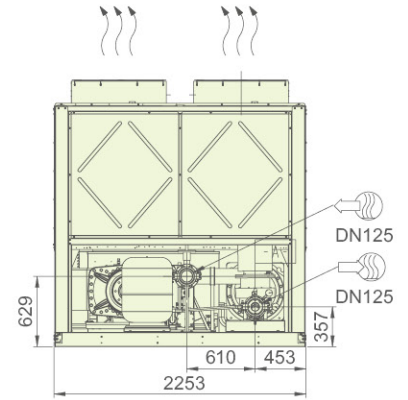
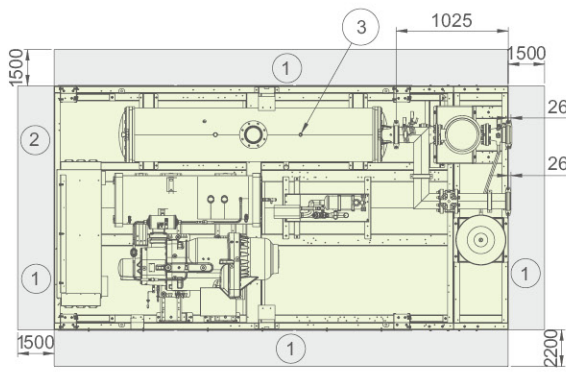
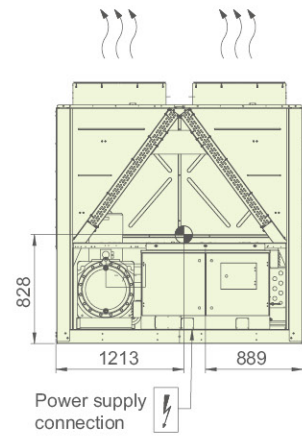
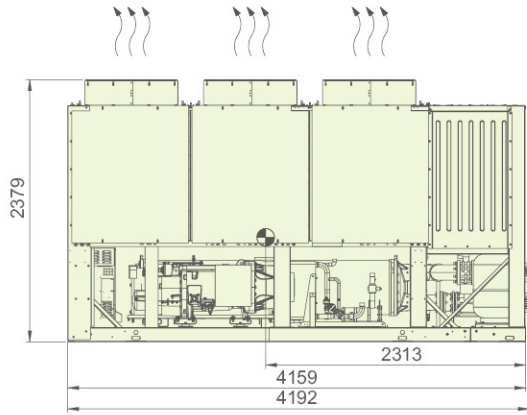

- ① Required clearances for maintenance
- ② Recommended space for evaporator tube removal
- ③ Safety valve
- Water inlet

- Water outlet
- Air outlet
- Power supply connection
- Center gravity

# Dimension Drawing

30KA0451A-0501APT116C

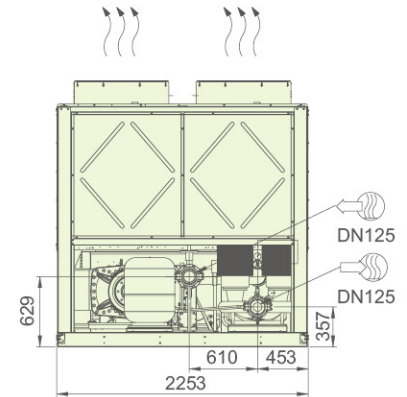
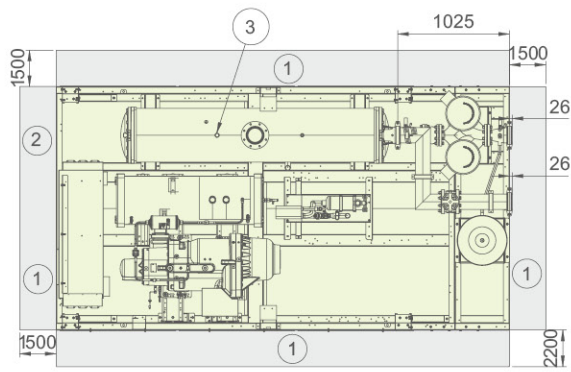
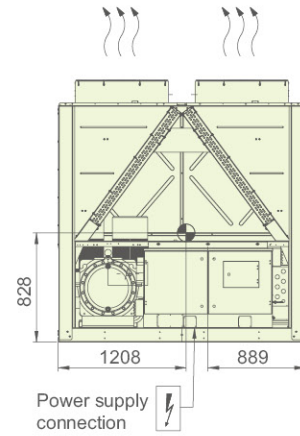
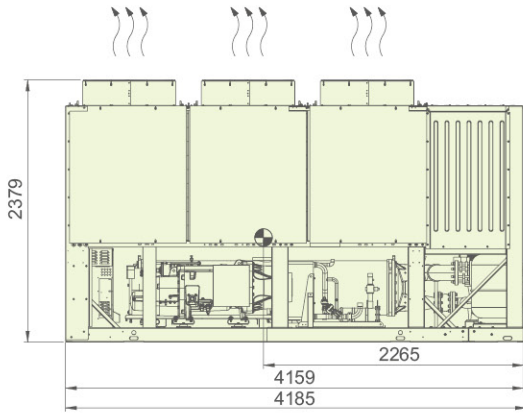

- ① Required clearances for maintenance
- ② Recommended space for evaporator tube removal
- ③ Safety valve
- Water inlet
- Water outlet
- Air outlet
- Power supply connection
- Center gravity

# Dimension Drawing

30KA0550A

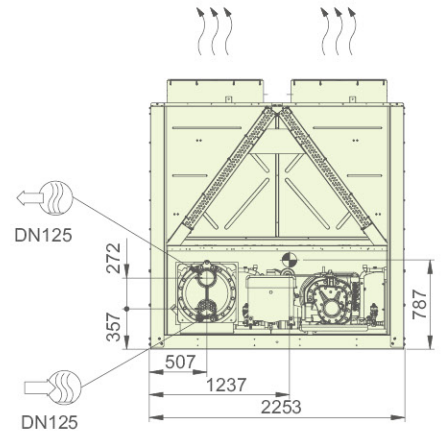
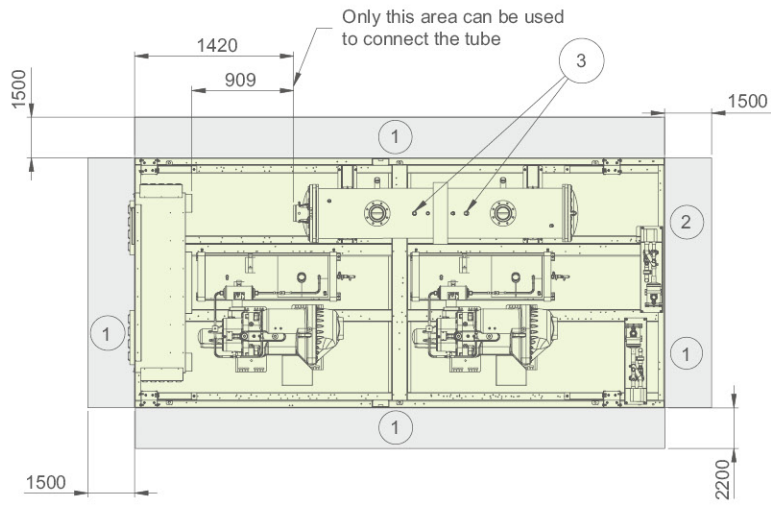
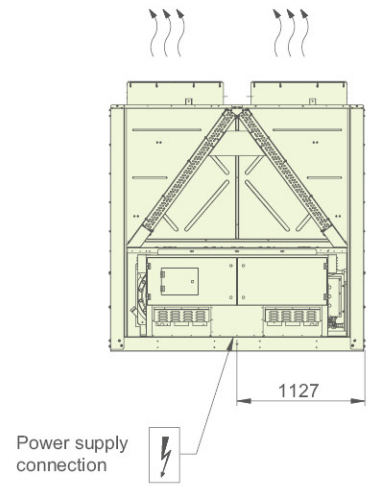
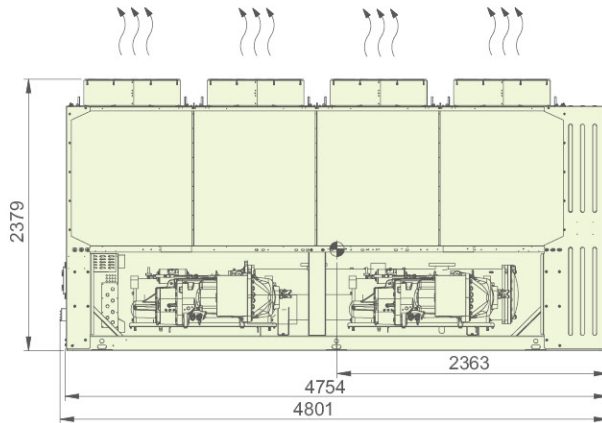

- ① Required clearances for maintenance
- ② Recommended space for evaporator tube removal
- ③ Safety valve
- Water inlet

- Water outlet
- Air outlet
- Power supply connection
- Center gravity

# Dimension Drawing

30KA0651A

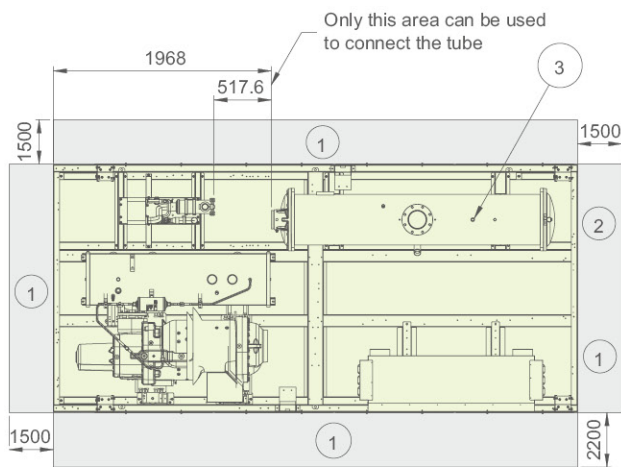
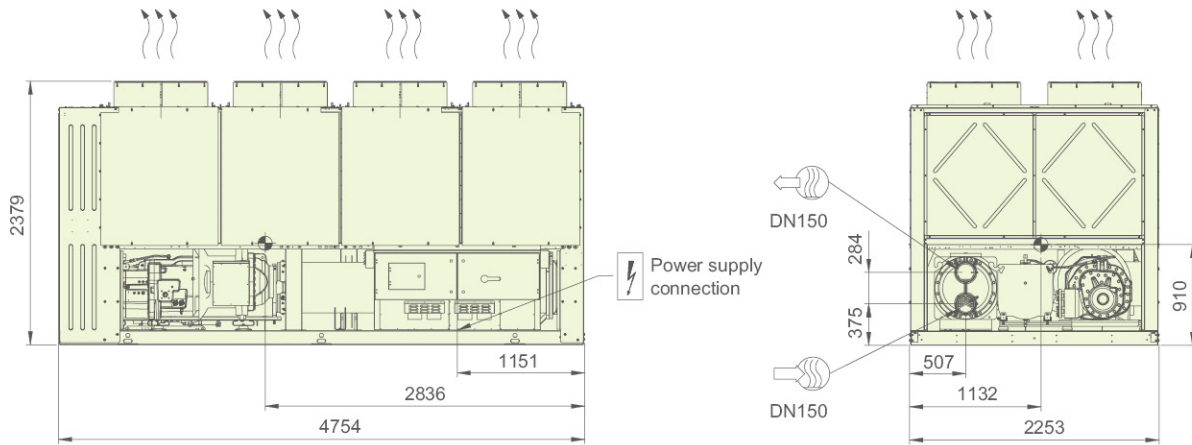

- ① Required clearances for maintenance
- ② Recommended space for evaporator tube removal
- ③ Safety valve
- Water inlet
- Water outlet
- Air outlet
- Power supply connection
- Center gravity

# Dimension Drawing

30KA0700A

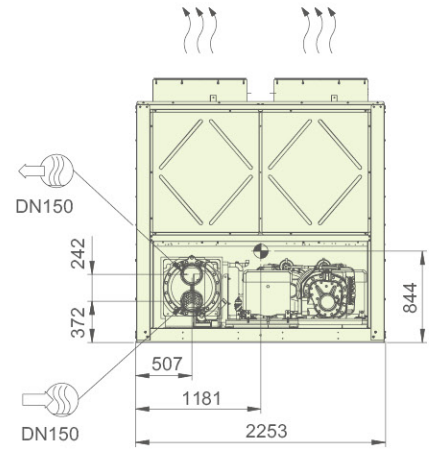
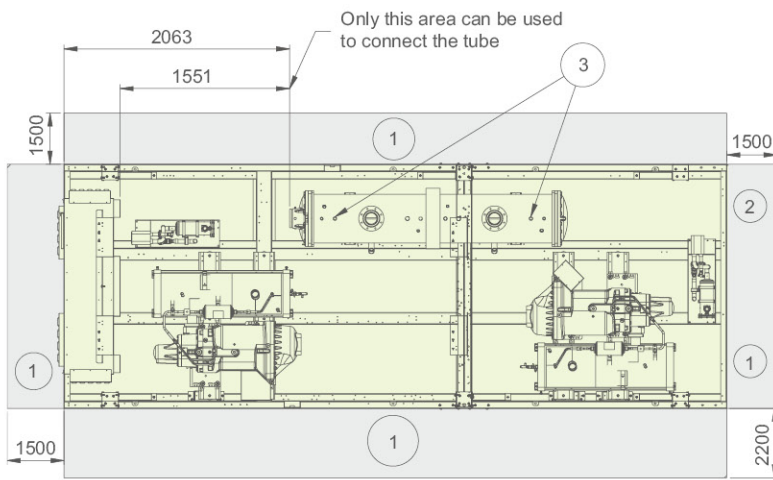
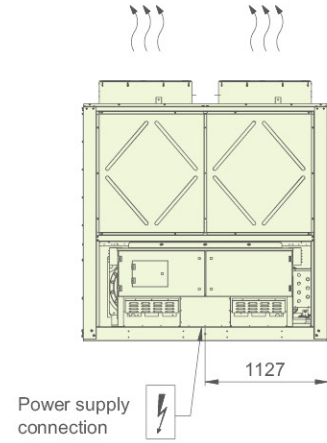
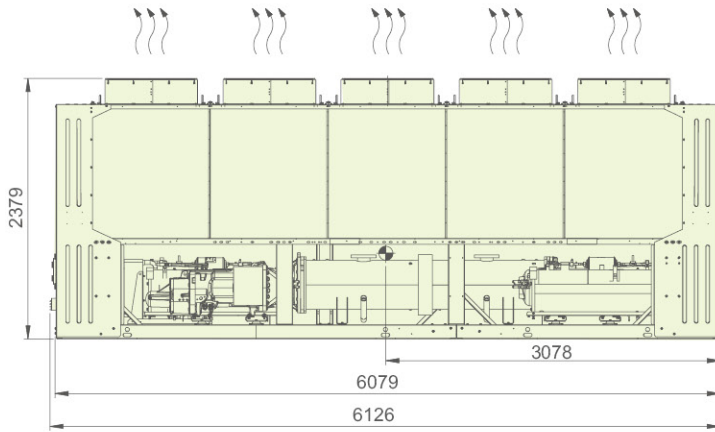

- ① Required clearances for maintenance
- ② Recommended space for evaporator tube removal
- ③ Safety valve
- Water inlet
- Water outlet
- Air outlet
- Power supply connection
- Center gravity



# Dimension Drawing

30KA0701A-0751A

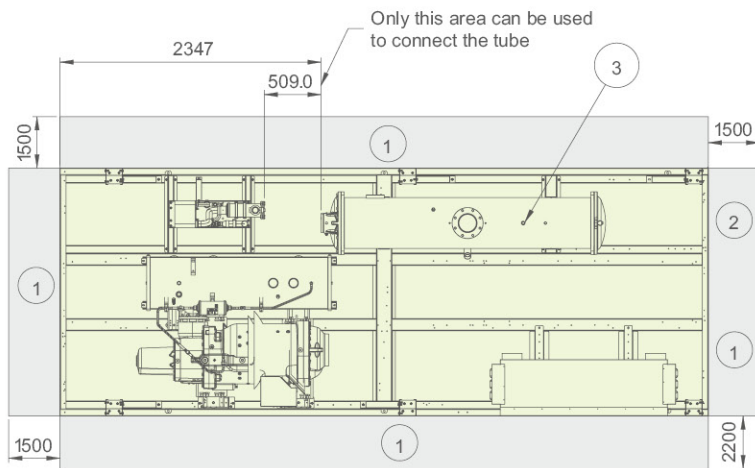
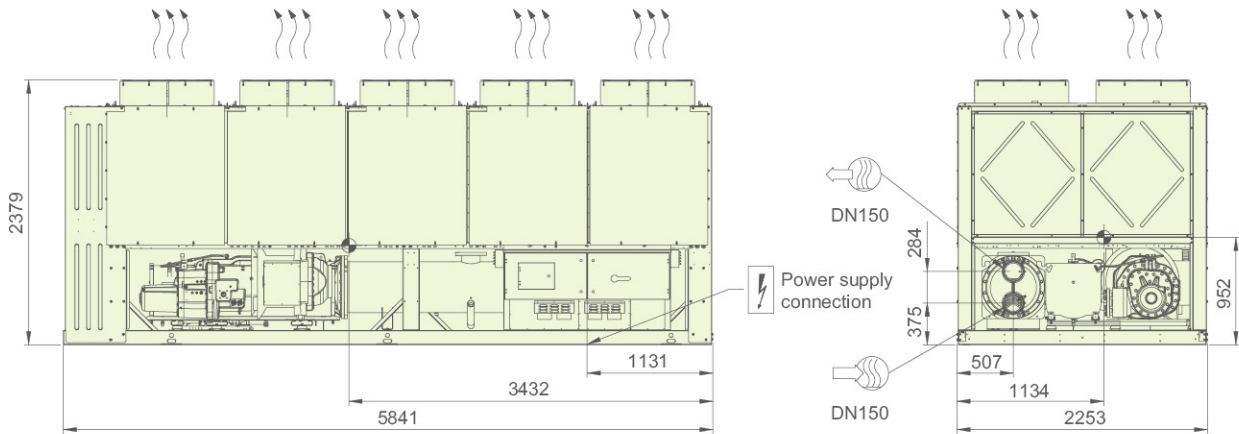

① Required clearances for maintenance

② Recommended space for evaporator tube removal

③ Safety valve

Water inlet

Water outlet

Air outlet

Power supply connection

Center gravity

# Dimension Drawing

30KA0750A

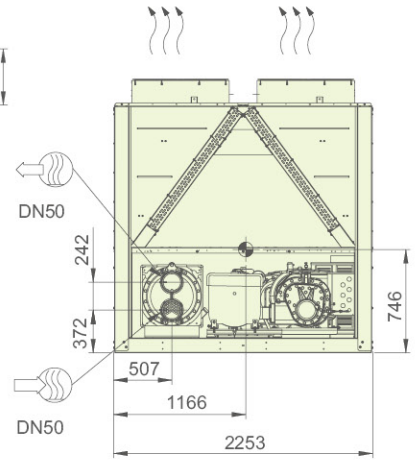
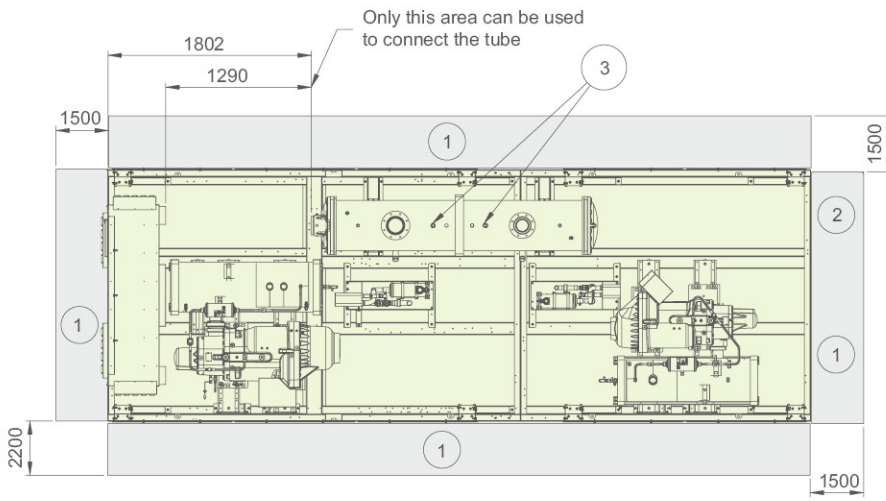
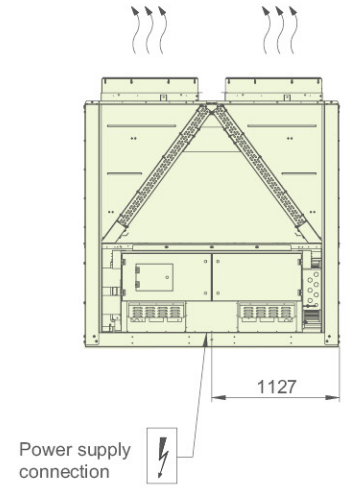
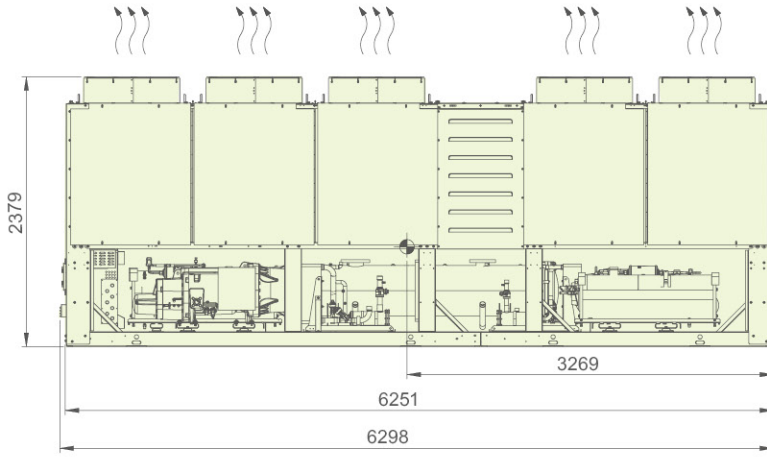

- ① Required clearances for maintenance
- ② Recommended space for evaporator tube removal
- ③ Safety valve
- Water inlet
- Water outlet
- Air outlet
- Power supply connection
- Center gravity

# Dimension Drawing

30KA0800A

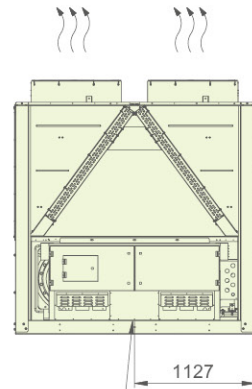
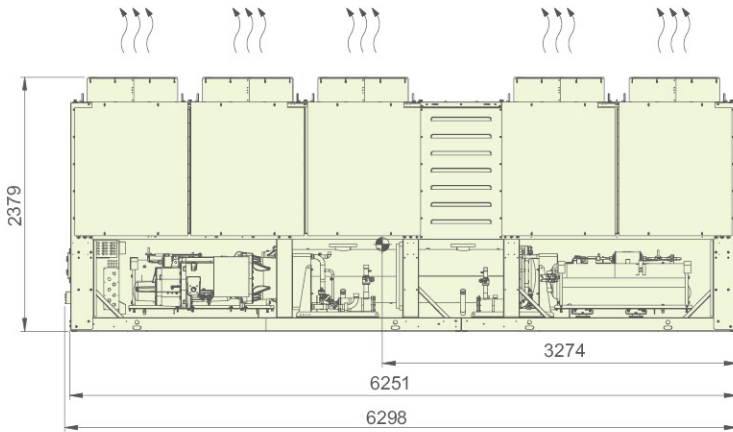

Power supply connection

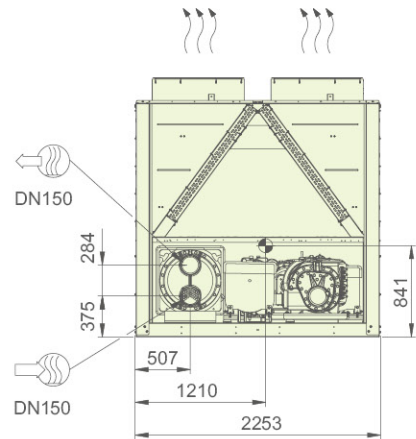
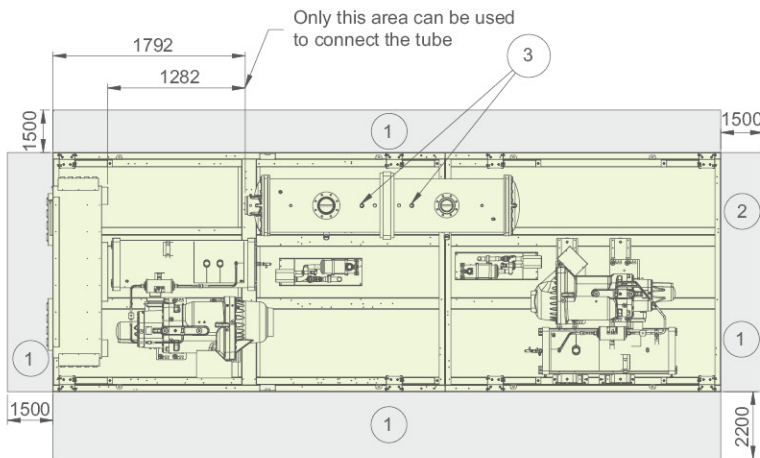

- ① Required clearances for maintenance
- ② Recommended space for evaporator tube removal
- ③ Safety valve
- Water inlet
- Water outlet
- Air outlet
- Power supply connection
- Center gravity

# Dimension Drawing

30KA0900A

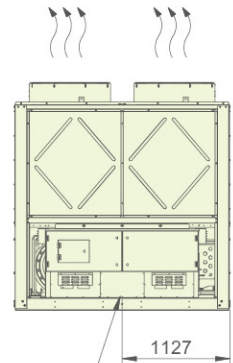
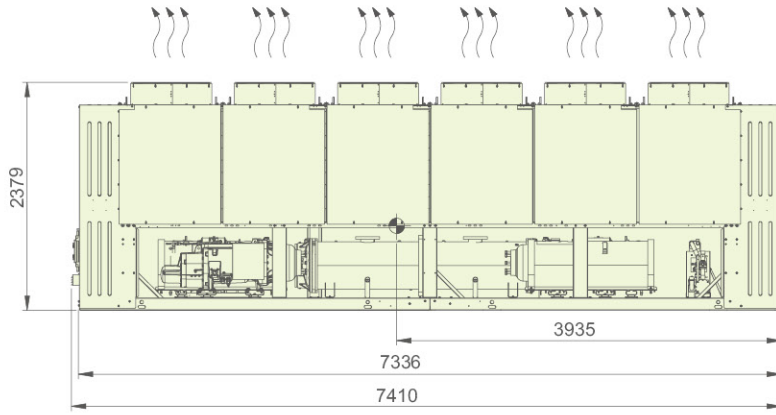

Power supply connection

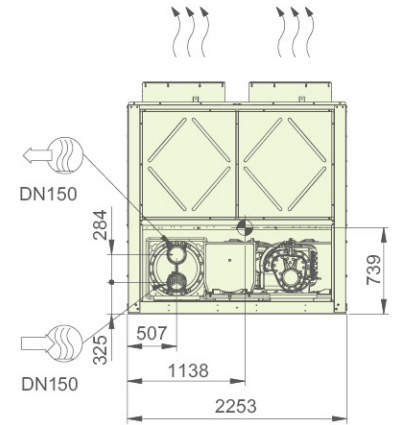
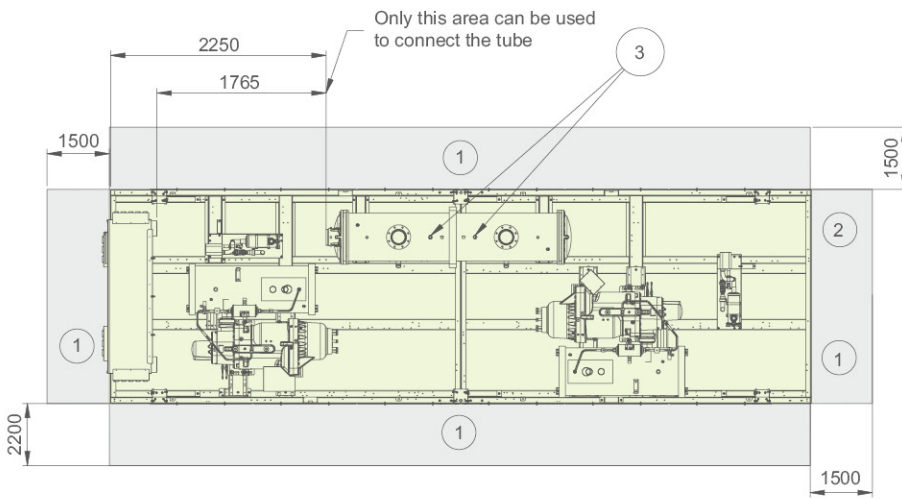

- ① Required clearances for maintenance
- ② Recommended space for evaporator tube removal
- ③ Safety valve
- Water inlet
- Water outlet
- Air outlet
- Power supply connection
- Center gravity

# Dimension Drawing

30KA1000A

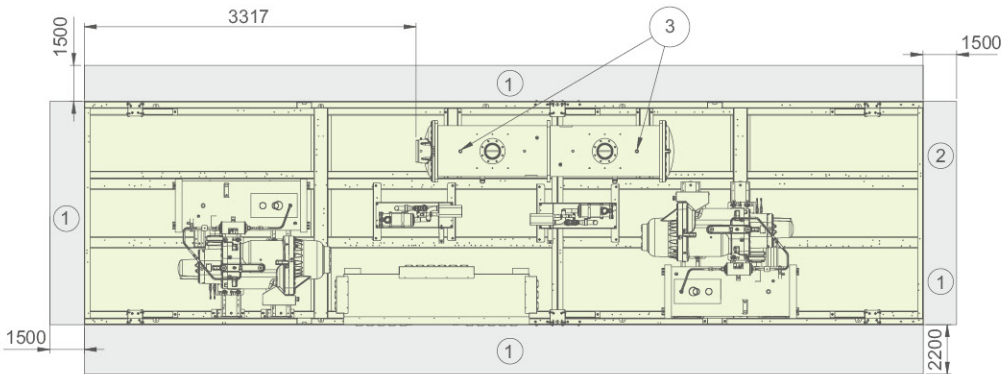
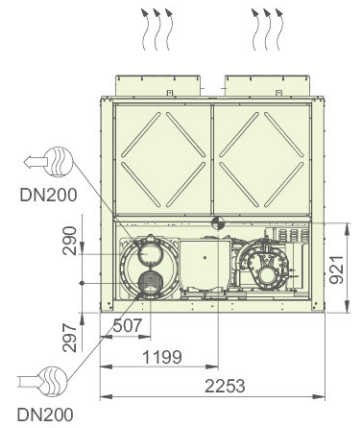
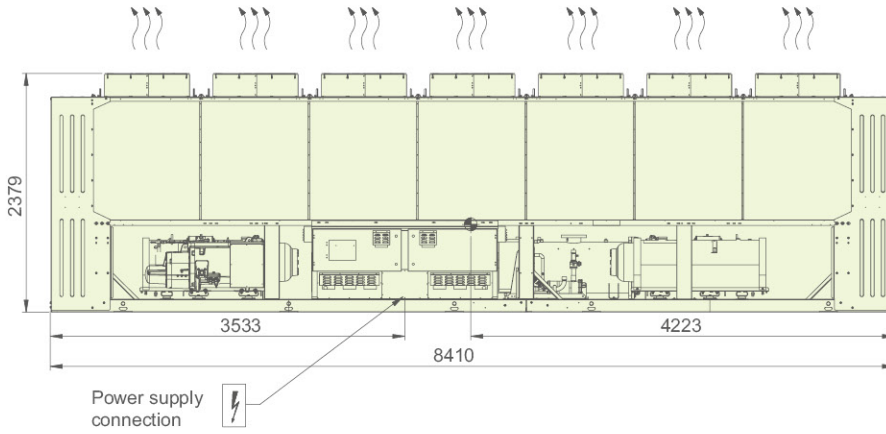

- ① Required clearances for maintenance
- ② Recommended space for evaporator tube removal
- ③ Safety valve
- Water inlet
- Water outlet
- Air outlet
- Power supply connection
- Center gravity

# Dimension Drawing

30KA1050A-1100A

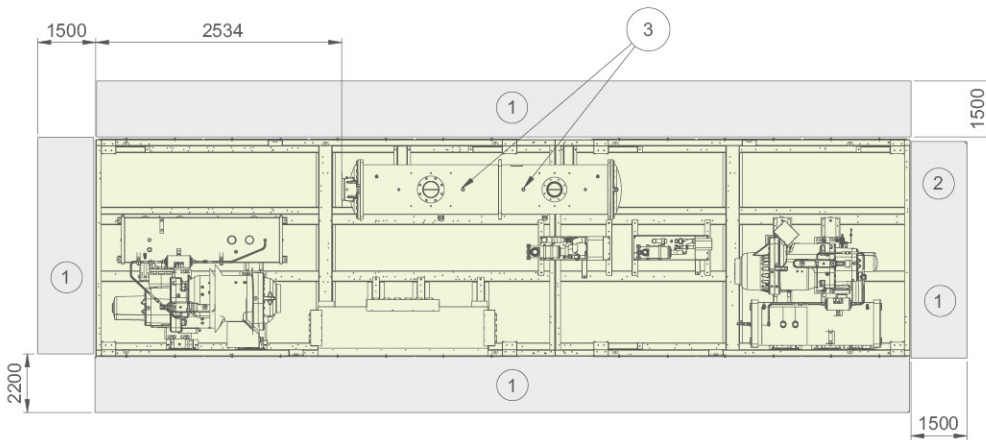
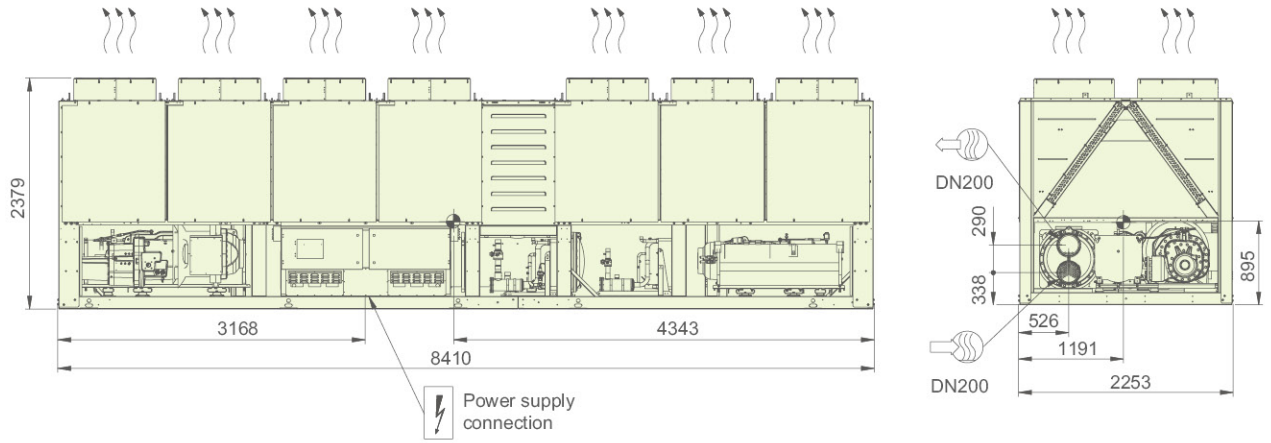

- ① Required clearances for maintenance
- ② Recommended space for evaporator tube removal
- ③ Safety valve
- Water inlet
- Water outlet
- Air outlet
- Power supply connection
- Center gravity

# Dimension Drawing

30KA1250A

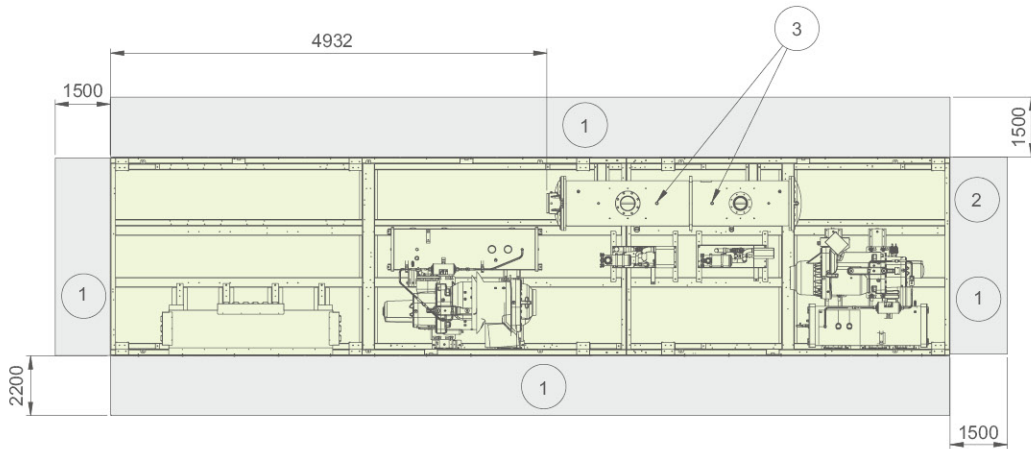
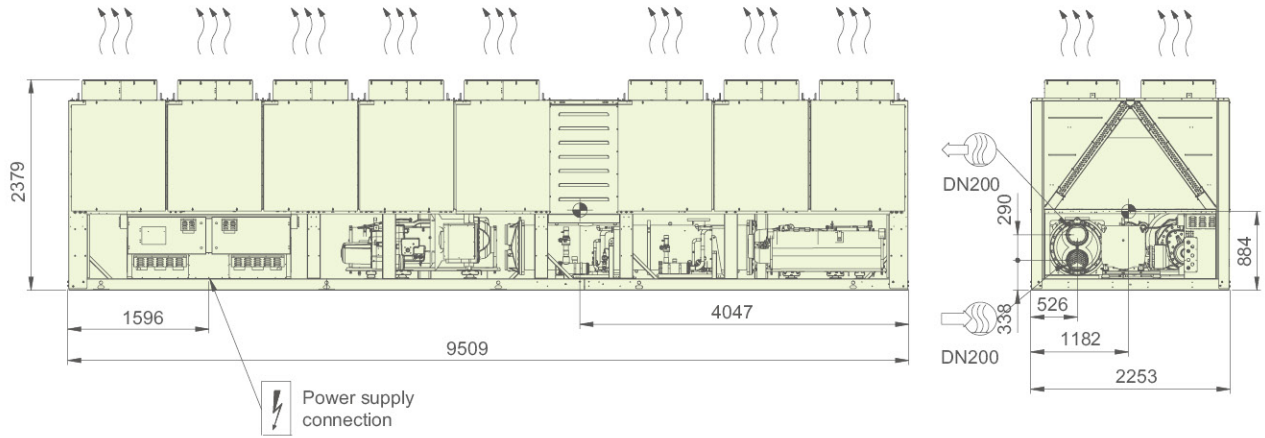

- ① Required clearances for maintenance
- ② Recommended space for evaporator tube removal
- ③ Safety valve
- Water inlet
- Water outlet
- Air outlet
- Power supply connection
- Center gravity

# Dimension Drawing

30KA1300A

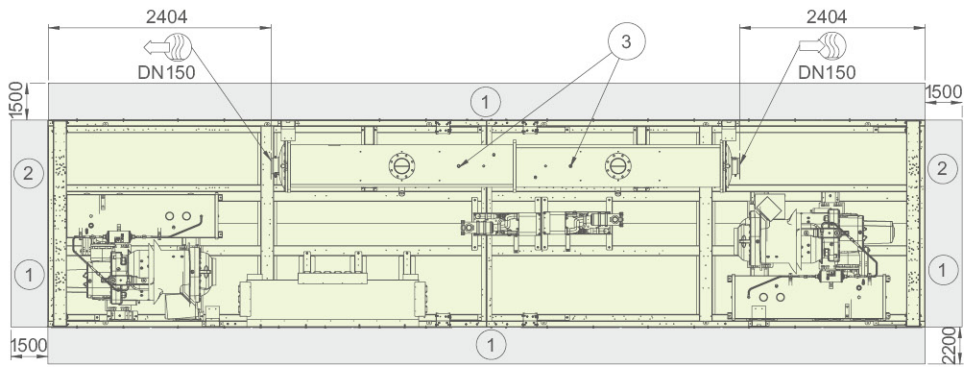
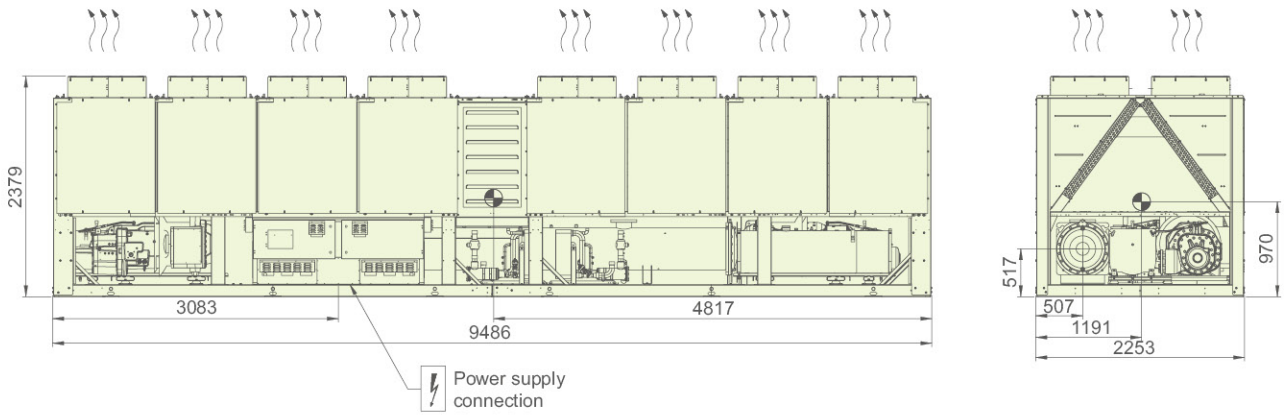

- |   |                           |
|---|---------------------------|
| ① Required clearances for maintenance           | ↔ DN150 Water outlet      |
| ② Recommended space for evaporator tube removal | ⋈ Air outlet              |
| ③ Safety valve                                  | ⚡ Power supply connection |
| ↔ DN150 Water inlet                             | ⊙ Center gravity          |



# Dimension Drawing

30KA1350A

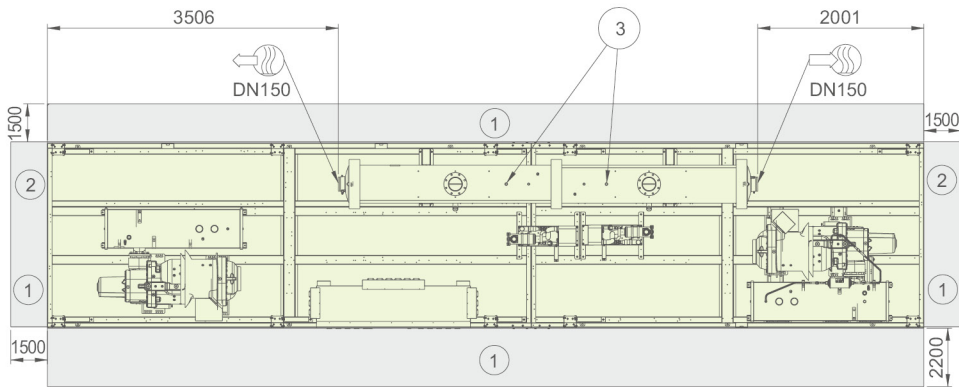
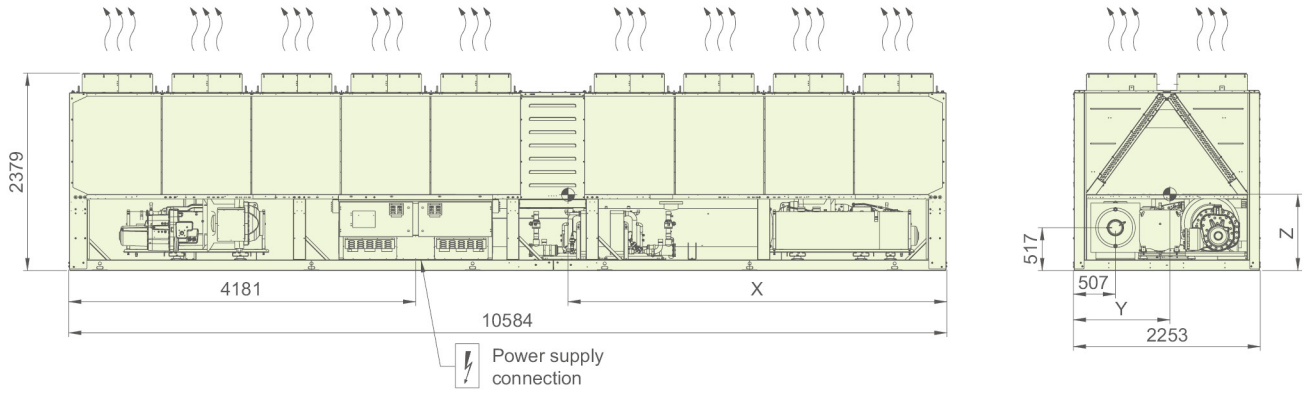

Unit model	Option	X (mm)	Y (mm)	Z (mm)
30KA1350A	-	4980	1202	886
30KA1350A	012	5255	1143	863

- ① Required clearances for maintenance
- ② Recommended space for evaporator tube removal
- ③ Safety valve
- Water inlet

- Water outlet
- Air outlet
- Power supply connection
- Center gravity

# Dimension Drawing

30KA1400A-1500A

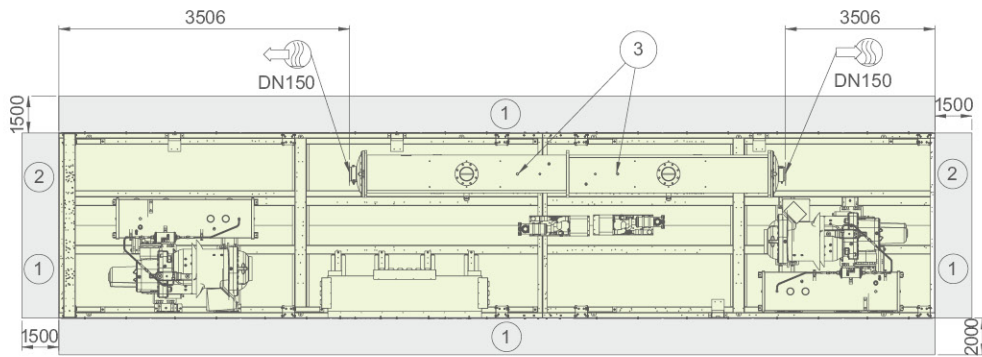
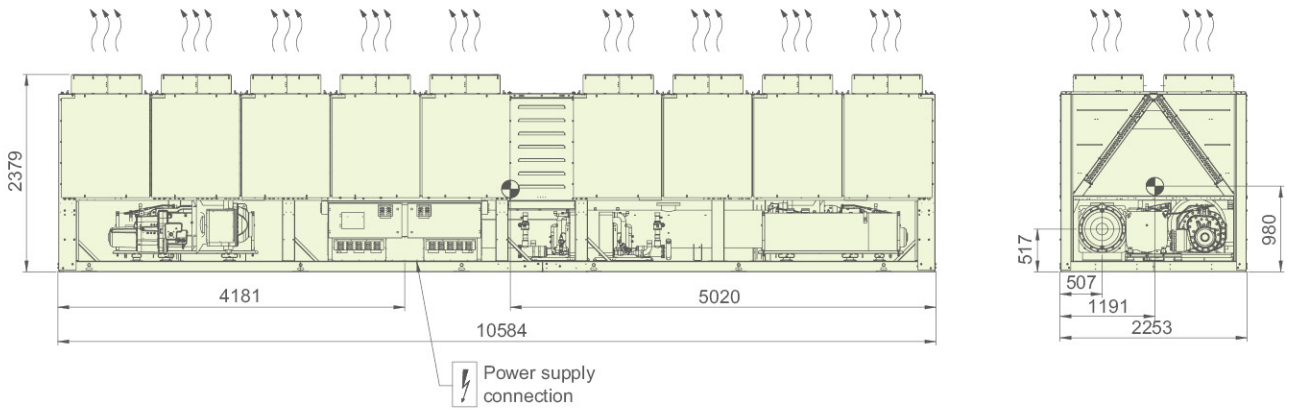

- |   |                         |
|---|-------------------------|
| ① Required clearances for maintenance           | Water outlet            |
| ② Recommended space for evaporator tube removal | Air outlet              |
| ③ Safety valve                                  | Power supply connection |
| Water inlet                                     | Center gravity          |

# Basement Drawing

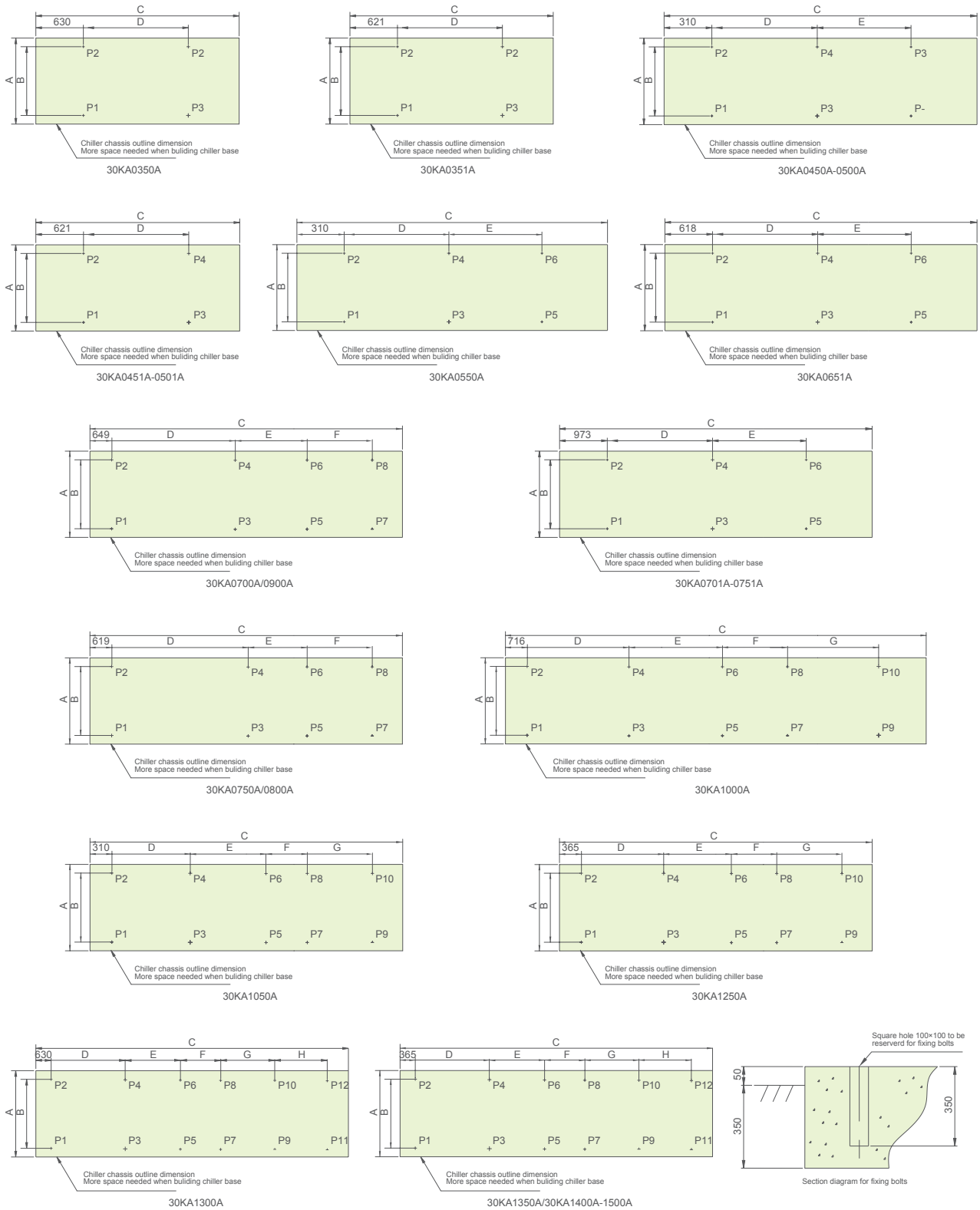

## Notes:

- 1.Anchor bolt specification: M20×300.
- 2.Anchor bolts located in P1,P2,P3...as shown in the drawing.
- 3.Single power connection point,and arrive from the bottom.
- 4.Reserve 120mm height space below the unit for power supply connection (unit aerial installation or cable slot arrangement in unit base)
- 5.Unit placement is the same as top view in outline drawing.
- 6.suggest to use spring isolator.

## Weight Distribution

Models	Dimensions, mm								Weight Distribution, kg												Operating Weight, kg
	A	B	C	D	E	F	G	H	P1	P2	P3	P4	P5	P6	P7	P8	P9	P10	P11	P12	
30KA0350A	2231	2139	3657	2420					927	757	950	776									3410
30KA0351A	2231	2139	3657	2420					955	881	664	612									3312
30KA0450A	2231	2139	4732	2056	1748				851	702	806	665	768	633							4425
30KA0451A	2231	2139	3657	2420					1203	964	832	669									3668
30KA0500A	2231	2139	4732	2056	1748				866	726	820	679	782	647							4510
30KA0501A	2231	2139	3657	2420					1205	967	835	671									3678
30KA0550A	2231	2139	4732	2056	1747				838	682	845	687	851	692							4595
30KA0651A	2231	2139	4732	1748	1748				587	593	797	806	1007	1018							4808
30KA0700A	2231	2139	6057	2360	1300	1096			698	631	688	621	682	616	677	611					5224
30KA0701A	2231	2139	5830	1942	2550				661	684	832	861	1056	1092							5186
30KA0750A	2231	2139	6229	2420	1256	1296	0	0	767	716	727	675	705	655	684	635					5561
30KA0751A	2231	2139	5830	1942	2550				662	685	834	863	1058	1094							5196
30KA0800A	2231	2139	6229	2420	1256	1296	0	0	812	696	769	658	746	638	722	617	0	0	0	0	5658
30KA0900A	2231	2139	7314	2360	1296	2360	0	0	866	848	811	794	780	764	725	710	0	0	0	0	6298
30KA1000A	2231	2139	8389	1650	1650	1365	2360	0	744	649	741	647	740	646	738	644	736	642	0	0	6927
30KA1050A	2231	2139	8389	2056	1748	1237	2420	0	820	727	804	713	790	701	781	692	762	676	0	0	7466
30KA1250A	2231	2139	9487	2550	1942	1592	2420	0	692	625	776	700	839	757	890	803	969	874	0	0	7925
30KA1300A	2231	2139	9464	1748	1748	1237	1748	1748	847	736	838	728	831	722	826	718	819	711	812	705	9293
30KA1350A	2231	2139	10562	2550	1942	1592	1748	1748	757	658	785	682	806	701	824	716	843	733	862	750	9117
30KA1400A	2231	2139	10562	2550	1942	1592	1748	1748	815	709	840	731	859	747	875	761	891	774	908	789	9699
30KA1500A	2231	2139	10562	2550	1942	1592	1748	1748	818	711	841	732	860	748	876	762	893	776	910	791	9748

### Notes:

- 1.Anchor bolt specification: M20×300.
- 2.Anchor bolts located in P1,P2,P3...as shown in the drawing.
- 3.Single power connection point,and arrive from the bottom.
- 4.Reserve 120mm height space below the unit for power supply connection (unit aerial installation or cable slot arrangement in unit base)
- 5.Unit placement is the same as top view in outline drawing.
- 6.suggest to use spring isolator.





Carrier improves the world around us; Carrier improves people's lives; our products and services improve building performance; our culture of improvement will not allow us to rest when it comes to the environment.



[www.carrier.com](http://www.carrier.com)

The Manufacturer reserves the right to change any product specifications without prior notices  
© All Rights Reserved Carrier

Version:	CAT_30KA_E-202006-08
Supersede:	CAT_30KA_E-202004-07
Effective date:	June, 2020